

**SALTUS®**  
SOLINGEN - GERMANY

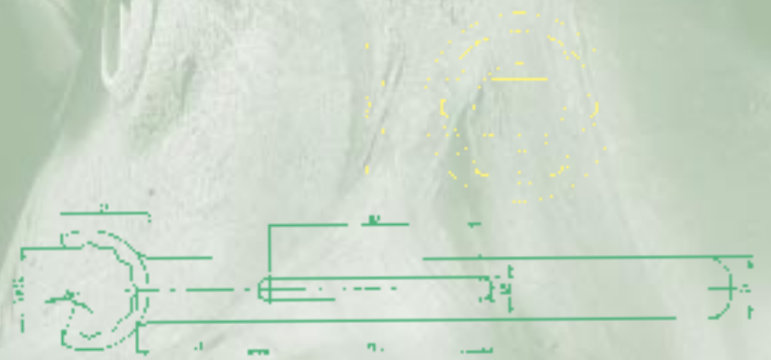

PRÄZISION IN DER TECHNIK



**HANDWERKZEUG PROGRAMM**

HANDTOOLS RANGE

GAMME D'OUTILLAGE À MAIN

PROGRAMA DE HERRAMIENTAS MANUALES

**SCHLÜSSEL FÜR DIE ZUKUNFT, SCHLÜ**

THE KEY TO THE FUTURE, THE KEY TO

LA CLEF DU FUTUR, LA CLEF DE LA RÉUSSITE

LA LLAVE HACIA EL FUTURO, LA

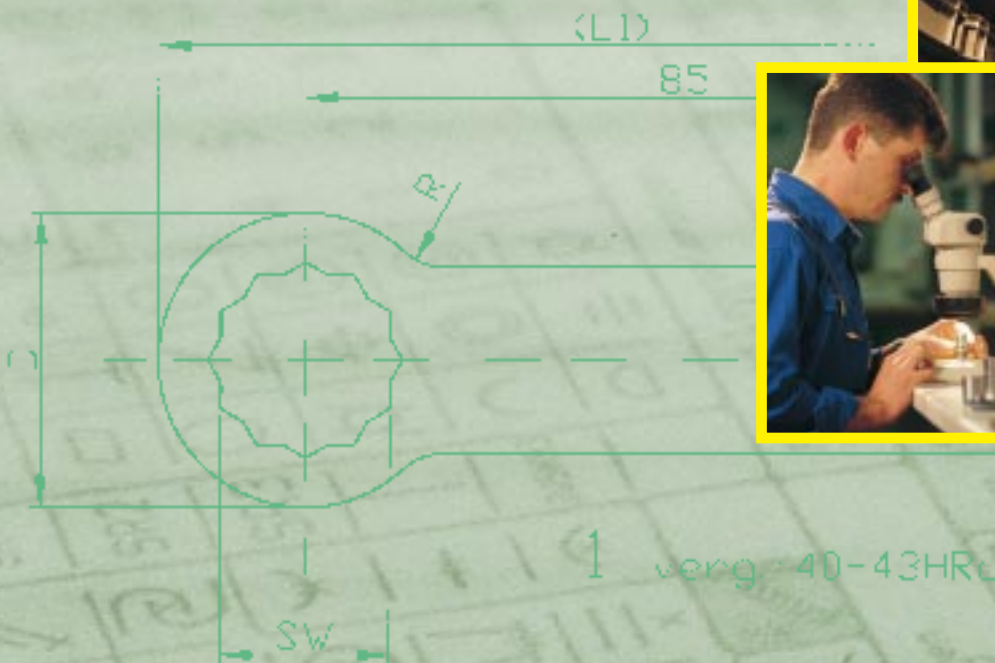

**D** Seit ihrer Gründung im Jahre 1919 stellt die Solinger SALTUS-WERK Max Forst GmbH Qualitätswerkzeuge für Automobilhersteller, für den Flugzeug- und Schiffsbau, den Maschinenbau und andere Industriesparten her. Wenn es um sichere Verschraubungen geht, sind überall auf der Welt sowohl den internationalen Normen entsprechende als auch kundenspezifische SALTUS-Werkzeuge im Einsatz, die nach Zeichnung oder Muster hergestellt werden. Durch ihre Qualität, Spezialisierung und Vielseitigkeit haben die SALTUS-Produkte eine starke Marktposition und einen internationalen Bekanntheitsgrad erreicht.

**GB** Since its foundation in 1919, SALTUS-WERK Max Forst GmbH has been producing high quality tools for automobile manufacturers, for aircraft construction and shipbuilding, mechanical engineering and other industry branches. When it comes to secure fastenings, SALTUS tools are in operation all over the world – tools according to international standards as well as those manufactured specifically to meet our customers' requirements. Their quality, specialisation and versatility have earned SALTUS-products a strong market position and great international renown. At SALTUS, our aim has always been to supply the industry with modern, effective tools and thus contribute to the quality and safety of the final product.

d'invention. Constamment orientés vers le progrès de la technique des procédés de production nouveaux ont été introduits. Des améliorations du produit ont lieu continuellement. Des développements nouveaux basés sur le domaine d'application ne font que renforcer le contact avec nos clients.

La collaboration entre les employés de SALTUS-WERK Max-Forst GmbH, aussi bien dans la production que dans l'administration est très étroite. Grâce à cela, la qualité dans le processus de travail, la productivité ainsi que dans l'information et le service auprès de la clientèle, ne fait que s'améliorer. A la suite de ces améliorations continues, l'usine a reçu en 1996 le certificat DIN ISO 9001 par la AGQS Remscheid.

De nos jours, l'usine SALTUS-WERK Max Forst GmbH n'est pas seulement reconnue pour sa production de très haute qualité en outils courants ou spéciaux mais aussi pour ses remarquables réalisations dans l'industrie automobiles internationales et dans bien d'autres domaines industriels.

Les produits SALTUS resteront dans le futur ce qu'ils ont toujours été: „Les clefs de l'avenir, les clefs du succès.“

## SSEL ZUM ERFOLG SUCCESS

## LLAVE HACIA EL ÉXITO

Unser Ziel ist es seit jeher, die Industrie mit modernen, zweckmäßigen Werkzeugen zu versorgen und damit ein Stück zur Sicherheit und Qualität der Endprodukte beizutragen. Aus diesem Bestreben ergaben sich im Laufe der Zeit viele Neuentwicklungen, die zu Gebrauchsmuster- bzw. Patentschutz führten. Stets am Fortschritt der Technik orientiert, wurden neue Fertigungsverfahren eingeführt, Produktverbesserungen erfolgen kontinuierlich. Neuentwicklungen, auf den Anwendungsbedarf abgestimmt, verstärken die enge Partnerschaft mit unseren Kunden. Durch die Zusammenarbeit der Mitarbeiter der SALTUS-WERK Max Forst GmbH in Produktion und Verwaltung wird die Qualität der Arbeitsprozesse, der Produktivität sowie der Kundenberatung und -betreuung ständig verbessert. In Folge dieser kontinuierlichen Verbesserungen wurde der SALTUS-WERK Max Forst GmbH 1996 durch die AGQS Remscheid das Zertifikat nach DIN ISO 9001 erteilt. Heute ist die SALTUS-WERK Max Forst GmbH nicht nur ein anerkannter Hersteller von Normal- und Spezialwerkzeugen höchster Qualität, sondern ebenso ein bedeutender Entwickler für die internationale Automobilindustrie und für viele andere Industriezweige. SALTUS-Produkte werden auch weiterhin das sein, was sie immer waren: „Schlüssel für die Zukunft, Schlüssel zum Erfolg.“

This endeavour has led to a great number of product refinements and developments and subsequently to many international patents. Always following the progress of technology, new production methods were incorporated while product enhancements are made continually. New developments, tuned to the users' requirements, strengthen our close partnership with our customer base even further.

The close co-operation of the SALTUS-WERK Max Forst GmbH's staff in production and administration leads to a continuous improvement of the quality of work processes, productivity and customer care. As a result, SALTUS-WERK Max Forst GmbH has been awarded the DIN ISO 9001 certificate by AGQS Remscheid in 1996.

Today, the SALTUS-WERK Max Forst GmbH is not only a widely acknowledged manufacturer of standard and special tools of premium quality, but an important developing partner for the entire automobile industry and numerous other branches. SALTUS-products will continue to be what they have always been: "The key to the future, the key to success."

**F** Depuis sa fondation en 1919, l'usine SALTUS-WERK Max Forst GmbH à Solingen, produit de l'outillage de qualité pour la production automobile, construction aéronautique, navale et machines ou autres secteurs de l'industrie. Partout dans le monde, quand il est question de vissage de sécurité aussi bien dans les normes internationales que dans des normes spécifiques aux clients, vous trouverez les produits SALTUS fabriqués d'après dessins ou modèles. Par leurs qualité, spécialisation et diversité, les produits SALTUS ont acquis une position forte sur le marché et sont internationalement reconnus. Notre but est, depuis toujours, de livrer des outils modernes, adaptés aux besoins de l'industrie et de contribuer à la sécurité et à la qualité du produit fini.

A la suite de ces efforts, se sont développées de nouvelles réalisations qui nous ont amenés de nouveaux modèles d'utilisation ou encore des protections et des brevets

**E** Desde su fundación en 1919, SALTUS-WERK Max Forst GmbH, ha producido herramientas de alta calidad para fabricantes de automóviles, constructores aeronáuticos, constructores navales, ingeniería mecánica y otros sectores de la industria. Cuando hablamos de FASTENINGS, las herramientas SALTUS se usan en todo el mundo, y están conformes con las normas internacionales, así mismo están fabricadas especialmente para satisfacer las necesidades de nuestros clientes. Su calidad, especialización y versatilidad han situado a los productos de SALTUS en una fuerte posición en el mercado, obteniendo renombre internacional. En SALTUS, nuestra meta ha sido siempre suministrar a la industria herramientas efectivas y de este modo contribuir a la calidad y la seguridad del producto final.

Este esfuerzo nos ha conducido a un buen número de productos de alta tecnología y a conseguir muchas patentes internacionales. Siempre siguiendo el progreso de la tecnología, vamos incorporando nuevos métodos de producción y nuevos productos. Los nuevos desarrollos, son para cubrir las necesidades de los usuarios, cooperando estrechamente con nuestros clientes en todos sus requerimientos.

La estrecha cooperación del personal de producción y administración en SALTUS-WERK Max Forst GmbH, nos conduce a una continua mejora de la calidad de los procesos de trabajo, productividad y al cuidado de los clientes. Como resultado, SALTUS WERK Max Forst GmbH, le ha sido concedido el certificado DIN ISO 9001, por AGQS Remscheid, en 1996.

Hoy SALTUS-WERK Max Forst GmbH, no es solo un reconocido fabricante de herramientas estándar y especiales de la mejor calidad es, además, un importante investigador de las necesidades de sus clientes, tanto en la industria automovilística, como en todos los otros campos. Los productos de SALTUS continuarán siendo lo que siempre han sido: "La llave hacia el futuro, la llave hacia el éxito".

# INHALTSVERZEICHNIS

INDEX

INDEX

TABLA DE MATERIAS

## Schraubenschlüssel, Spezialknarren

Spanners, Special Ratchets  
Clés de serrage, Clés à cliquet  
Llaves, Chicharras especiales

4 – 15

## Steckschlüssel, Winkelschraubendreher

Nut Spinners, Key Wrenches  
Clés à douilles, Clés mâles  
Llaves, Llaves hexagonales

16 – 25

## Schraubendreher

Screwdrivers  
Tournevis  
Destornilladores

26 – 33

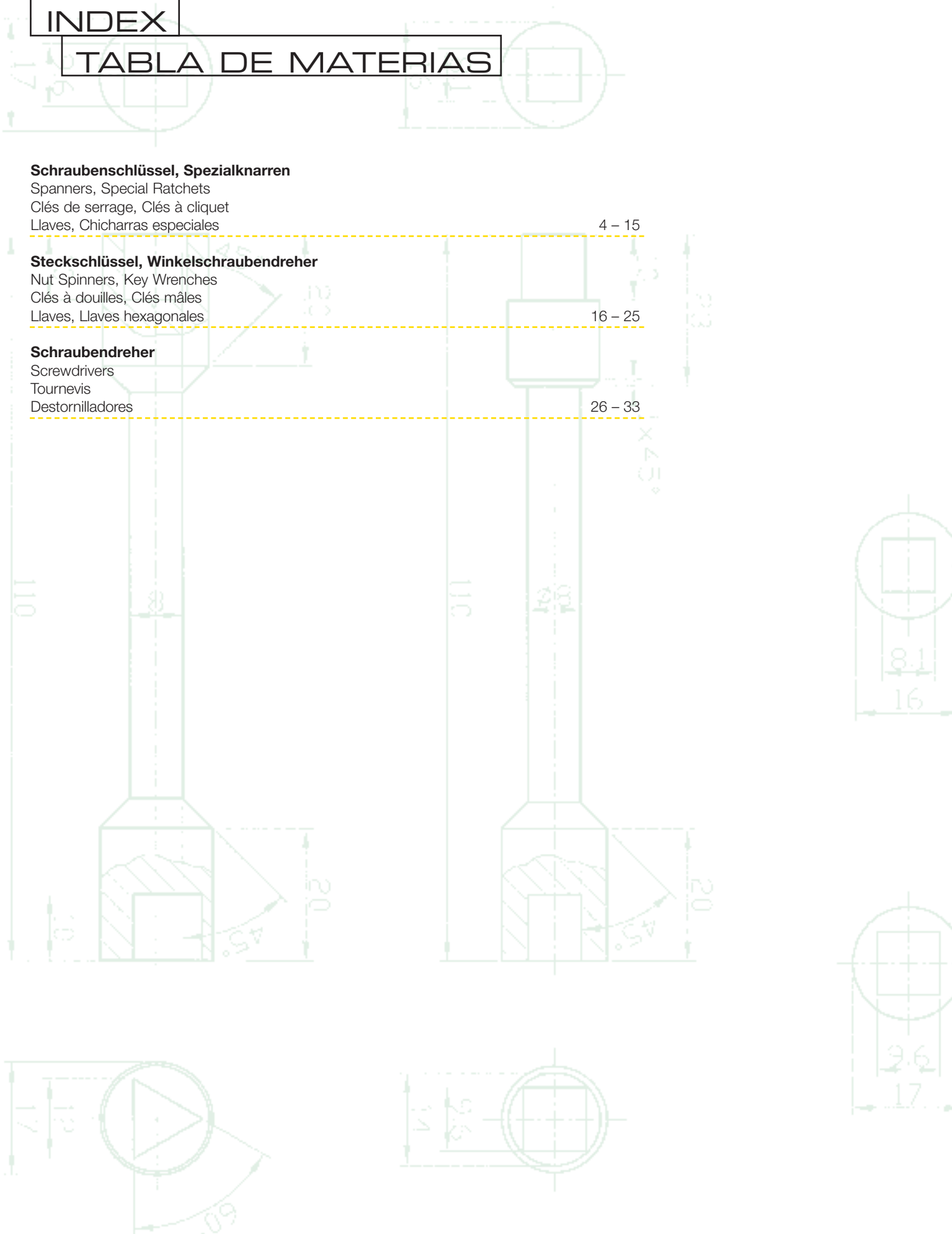

**Steckschlüsseinsätze, Betätigungswerkzeuge, Steckschlüsselsätze**

Sockets, Handles and Accessories, Socket Sets

Douilles, Accessoires, Jeux de douilles

Bocas, Accesorios, Juegos de bocas

34 – 59

**KFZ-Spezialwerkzeuge**

Automotive and Special Tools

Outils automobiles

Herramientas para el Automóvil

60 – 72

**Gummi-Kompositions-, Gummi-Elastik-, Plastik-, Nylon- und Schlosser-Hämmer**

Rubber-, Plastic-, Nylon- and Machinists'-Hammers

Maillets caoutchouc, plastiques, nylon, Marteaux

Martillos de goma, de plástico, de nylon y para mecánicos

62 – 64

**Scheren, Lötlwasser- und Salzsäureflaschen, Schläuche**

Scissors, Fluid and Acid-bottles, Tubings

Ciseaux, Décapant, flacon, Acide chlorhydrique, Tuyaux

Tijeras, Botellas para líquido y para ácido clorhídrico, Mangas

71 – 72

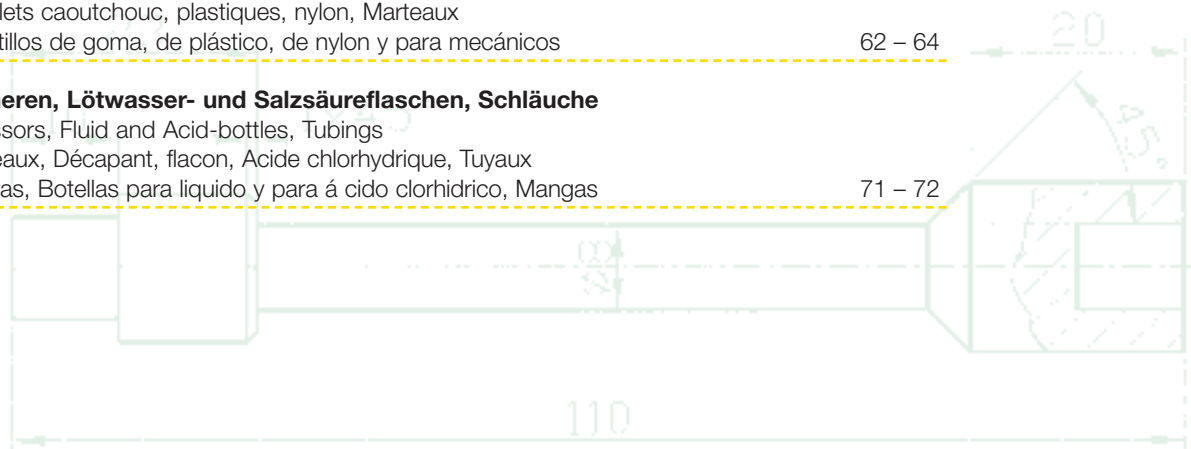



120°



CL11

SCHRAUBENSCHLÜSSEL, SPEZIALKLN

WRENCHES, SPECIAL RATCHETS

CLÉS DE SERRAGE, CLÈS À CLIQUETS

LLAVES, CHICHARRAS

## D PRODUKTBESCHREIBUNG

### SCHRAUBENSCHLÜSSEL, SCHRAUBWERKZEUGE, SPEZIALKNARREN IN VERSCHIEDENEN AUSFÜHRUNGEN NACH DIN/ISO UND IN SPEZIALAUSFÜHRUNGEN, SONDERAUSFÜHRUNGEN.

Alle diese technischen Arbeitsmittel werden nach den allgemein anerkannten Regeln der Technik (z.B. DIN/ISO Normen) gefertigt. Nach diesen Normen wird auch die Gleichmäßigkeit der Schraubenschlüssel und Schraubwerkzeuge hinsichtlich ihrer Gebrauchstauglichkeit festgelegt, insbesondere durch die vorgeschriebene Härte und das vorgeschriebene Drehmoment. Durch sorgfältige Konstruktion und Berechnung werden bei SALTUS-Werkzeugen hohe Drehmomente bei geringen Abmessungen erreicht. SALTUS-Schraubenschlüssel werden unter Verwendung von hochwertigem Chrom-Vanadium-Stahl im Gesenk geschmiedet, anschließend mechanisch bearbeitet und dann einer Wärmebehandlung unterzogen, die für extreme Belastbarkeit sorgt und außerdem eine außergewöhnliche Langlebigkeit garantiert. Die grat- und zunderfreie Oberfläche wird schließlich dauerhaft korrosionsschutz. Sehr gute Anlageflächen in der Hand gewährleisten die Sicherheit für große Kraftübertragung. SALTUS-Schlüssel übertreffen die Anforderungen von nationalen und internationalen Normen. Das SALTUS-Qualitätssicherungsmanagement sorgt für eine konsequente Kontrolle nach jedem Arbeitsschritt – bei Schraubenschlüsseln wie bei allen anderen SALTUS-Produkten.

### GB PRODUCT DESCRIPTION OPERATING INSTRUCTIONS

### US SPANNERS, DIFFERENT TYPES OF FASTENING TOOLS ACCORDING TO DIN/ISO AND SPECIAL VERSIONS

All these tools are manufactured according to universally established rules such as DIN- and ISO-Standards. These norms specify the regularity of spanners and fastening tools in terms of their usability,

especially by the stipulated hardness and torque. Due to precise construction and calculation, SALTUS-tools achieve high torque despite their small dimensions. SALTUS-spanners are drop-forged using high-grade Chrome-Vanadium-steel, then processed mechanically and subjected to a heat treatment that gives them extreme load capacity and guarantees exceptionally long tool life. The burr free surface then receives a lasting corrosion-protection. Excellent grip provides the safety for transmission of great forces.

SALTUS-spanners meet or even surpass the requirements of all national and international norms. The SALTUS quality management ensures strict controls following each step in the work process – for spanners as well as for all other SALTUS products.

## F DESCRIPTIF TECHNIQUE CONSEILS D'UTILISATION

### CLEFS DE SERRAGE, OUTILS DE SERRAGE

Clefs de serrage, outils de serrage dans des exécutions variées d'après DIN/ISO et dans des exécutions spéciales. Tous ces moyens de travaux techniques suivent les règles générales et reconnues (par exemple dans les normes DIN/ISO). C'est aussi d'après ces normes que l'on fixe l'homogénéité des clefs et outils de serrage selon leurs capacités de fonctionnement, en particulier selon la dureté imposée et le couple de serrage imposé. Grâce à une construction et à des calculs minutieux on atteint des couples de serrage très forts avec des dimensions minimales.

Les Clefs de serrage SALTUS sont forgées en matrice avec un acier chrome vanadium de première qualité, ensuite travaillées mécaniquement puis passées sous un traitement thermique qui entraîne une extrême endurance et qui garantit en plus, une longévité exceptionnelle. La surface sans bavures et calamine reçoit enfin une protection anti-corrosive de longue durée. Une poignée ergonomique vous assure une grande sécurité pour la transmission de force.

Les clefs SALTUS surpassent toutes les exigences des normes nationales et internationales. Le management de la qualité SALTUS sollicite un contrôle conséquent après chaque échelon de production aussi bien des clefs à écrous que des autres produits de la maison.

## E LLAVES, DIFERENTES TIPOS DE CARRACAS SEGÚN NORMAS DIN/ISO Y VERSIONES ESPECIALES.

Todas estas herramientas están fabricadas según las establecidas normas universales tales como los estándares DIN e ISO. Estas normas especifican la regularidad de las llaves y las herramientas de apriete, en términos de su utilidad, especialmente por la estipulada dureza y potencia. Debido a la construcción precisa y calculada, las herramientas SALTUS alcanzan una alta potencia a pesar de sus pequeñas dimensiones.

Las Llaves SALTUS son forjadas con aceros de alto contenido de cromo-vanadio, están procesadas mecánicamente y sujetas a un tratamiento térmico que les da gran capacidad y excepcionales garantías para la larga vida de la herramienta. La superficie libre de rebaba y escoria recibe la última capa de protección anticorrosiva. El excelente agarre proviene de seguridad por transmisión de fuerzas.

Las Llaves SALTUS, alcanzan y sobrepasan los requerimientos de todas las normas nacionales e internacionales. La dirección de calidad de SALTUS asegura controles estrictos seguidos durante todo el proceso, tanto para las llaves como para todos los productos SALTUS.

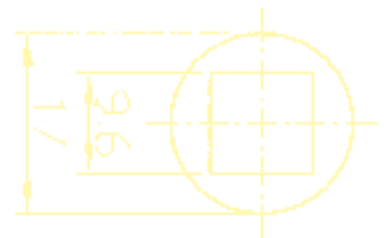

ARREN

ESPECIALES

## SCHRAUBENSCHLÜSSEL, SPEZIALKNARREN

WRENCHES, SPECIAL RATCHETS

CLÉS DE SERRAGE, CLÉS À CLIQUETS

LLAVES, CHICHARRAS ESPECIALES

3 = 1



**Gabel-Gelenksteckschlüssel, verchromt, der jeweils über 180° verstellbare Kopf bleibt durch die eingebaute Federscheibe in jeder gewünschten Lage stehen**

Combined Open End and Socket Wrenches, chrome plated. The 180° adjustable head remains firm in any position by means of a spring

Clés combinées à fourche et à douille articulée, chromées. La douille est orientable à 180° et reste dans toutes les positions désirées à l'aide d'un ressort de maintien

Llaves combinadas, cromadas, cabeza ajustable más de 180° queda firme en cualquier posición deseada

Bestell-Nr. Part No. Référence No. Referencia No.	 mm	Länge Length Longueur Largo mm	Gewicht Weight Poids Peso g
00 0301 0008	8	140	40
00 0301 0009	9	140	40
00 0301 0010	10	160	70
00 0301 0011	11	160	70
00 0301 0012	12	175	100
00 0301 0013	13	170	100
00 0301 0014	14	195	150
00 0301 0015	15	195	155
00 0301 0016	16	215	215
00 0301 0017	17	215	220
00 0301 0018	18	235	250
00 0301 0019	19	235	250
00 0301 0020	20	260	335
00 0301 0021	21	260	340
00 0301 0022	22	285	390
00 0301 0023	23	285	400
00 0301 0024	24	285	400

### Drehstift für alle Größen

Tommy-Bar for all sizes

Broche pour toutes les dimensions

Maneral escalonado para todos tamaños

Bestell-Nr. Part No. Référence No. Referencia No.	Länge Length Longueur Largo mm	Gewicht Weight Poids Peso g
00 0301 0000	200	62

3 = 1



### Sätze

Sets

Jeux

Juegos

Bestell-Nr. Part No. Référence No. Referencia No.	Zusammenstellung Contents Composition Composición	Gewicht Weight Poids Peso g
00 0301 7117	3 = 1/17 8, 9, 10, 11, 12, 13, 14, 15, 16, 17, 18, 19, 20, 21, 22, 23, 24	3565
00 0301 7217	3 = 1/17 T 8, 9, 10, 11, 12, 13, 14, 15, 16, 17, 18, 19, 20, 21, 22, 23, 24	3875
00 0301 7110	3 = 1/10 KT 8, 9, 10, 11, 13, 14, 16, 17, 18, 19	1480

**Doppelmaulschlüssel  
nach DIN 3110/ISO 3318,  
verchromt**

Double Open End Wrenches,  
DIN 3110/ISO 3318, chrome plated

Clés à fourches, DIN 3110/  
ISO 3318, chromées

Llaves de dos bocas,  
DIN 3110/ISO 3318, cromadas

Bestell-Nr. Part No. Référence No. Referencia No.		Länge Length Longueur Largo	Gewicht Weight Poids Peso
	mm	mm	g
00 0050 0607	6 x 7	130	30
00 0050 0809	8 x 9	143	45
00 0050 1011	10 x 11	157	55
00 0050 1213	12 x 13	175	75
00 0050 1415	14 x 15	190	100
00 0050 1617	16 x 17	207	175
00 0050 1819	18 x 19	223	210
00 0050 2022	20 x 22	235	245
00 0050 2123	21 x 23	250	245
00 0050 2427	24 x 27	270	315
00 0050 2528	25 x 28	285	375
00 0050 3032	30 x 32	300	500

50



**Sätze**

Sets

Jeux

Juegos

Bestell-Nr. Part No. Référence No. Referencia No.	Zusammenstellung Contents Composition Composición	Gewicht Weight Poids Peso
		g
00 0050 7108	50/8 6 x 7, 8 x 9, 10 x 11, 12 x 13, 14 x 15, 16 x 17, 18 x 19, 20 x 22	840
00 0050 7110	50/10 6 x 7, 8 x 9, 10 x 11, 12 x 13, 14 x 15, 16 x 17, 18 x 19, 20 x 22, 21 x 23, 24 x 27	1400
00 0050 7112	50/12 6 x 7, 8 x 9, 10 x 11, 12 x 13, 14 x 15, 16 x 17, 18 x 19, 20 x 22, 21 x 23, 24 x 27, 25 x 28, 30 x 32	2300
00 0050 7408	50/8 KT 6 x 7, 8 x 9, 10 x 11, 12 x 13, 14 x 15, 16 x 17, 18 x 19, 20 x 22	900

50



Andere Satzzusammenstellungen nach Kundenwunsch  
Different assortments on request  
Autres compositions à la demande  
Otros composiciones a petición

**Doppelringschlüssel  
für Außentorxschrauben,  
gerade, verchromt**

Double Box Wrenches,  
for screws with Torx-outside profile,  
straight, chrome plated

Clés polygonales pour vis Torx, à  
empreinte mâle, droites, chromées

Llaves de dos bocas para tornillos  
Torx exterior, planas, cromadas

Bestell-Nr. Part No. Référence No. Referencia No.		Länge Length Longueur Largo	Gewicht Weight Poids Peso
		mm	g
00 0278 0608	E 6 x E 8	115	20
00 0278 1012	E 10 x E 12	142	33
00 0278 1418	E 14 x E 18	180	75
00 0278 2024	E 20 x E 24	225	162

278



# SCHRAUBENSCHLÜSSEL, SPEZIALKNARREN

WRENCHES, SPECIAL RATCHETS

CLÉS DE SERRAGE, CLÉS À CLIQUETS

LLAVES, CHICHARRAS ESPECIALES

## 450



### Doppelringschlüssel, tief gekröpft, nach DIN 838/ISO 10104, verchromt

Double Box Wrenches deep offset, DIN 838/ISO 10104, chrome plated

Clés polygonales, contre-coudées, DIN 838/ISO 10104, chromées

Llaves de dos bocas en estrella, DIN 838/ISO 10104, acodadas, cromadas

Bestell-Nr. Part No. Référence No. Referencia No.		Länge Length Longueur Largo	Gewicht Weight Poids Peso
	mm	mm	g
00 0450 0607	6 x 7	170	45
00 0450 0809	8 x 9	185	65
00 0450 1011	10 x 11	205	90
00 0450 1213	12 x 13	225	105
00 0450 1415	14 x 15	235	150
00 0450 1617	16 x 17	255	195
00 0450 1819	18 x 19	295	265
00 0450 2022	20 x 22	310	325
00 0450 2123	21 x 23	320	350
00 0450 2427	24 x 27	340	445
00 0450 2528	25 x 28	355	540
00 0450 3032	30 x 32	375	600

## 450



### Sätze

Jeux

Sets

Juegos

Bestell-Nr. Part No. Référence No. Referencia No.	Zusammenstellung Contents Composition Composición	Gewicht Weight Poids Peso
		g
00 0450 7108	450/8 6 x 7, 8 x 9, 10 x 11, 12 x 13, 14 x 15, 16 x 17, 18 x 19, 20 x 22	1215
00 0450 7110	450/10 6 x 7, 8 x 9, 10 x 11, 12 x 13, 14 x 15, 16 x 17, 18 x 19, 20 x 22, 21 x 23, 24 x 27	2005
00 0450 7112	450/12 6 x 7, 8 x 9, 10 x 11, 12 x 13, 14 x 15, 16 x 17, 18 x 19, 20 x 22, 21 x 23, 24 x 27, 25 x 28, 30 x 32	3150
00 0450 7408	450/8 KT 6 x 7, 8 x 9, 10 x 11, 12 x 13, 14 x 15, 16 x 17, 18 x 19, 20 x 22	1400

### Artikel-Nr.

Part No.  
Référence No.  
Referencia No.

<b>470</b>	Zug-Ringschlüssel Heavy Duty Box Wrenches Clés lourdes polygonales Llaves de tracción
<b>894</b>	Einmaulschlüssel nach DIN 894 Single Open End Wrenches Clés à fourches, simple Llaves de una boca
<b>895</b>	Doppelmaulschlüssel nach DIN 895 Double Open End Wrenches Clés à fourches Llaves de dos bocas

Auf Anfrage / On request / Sur demande / A petición

**Ring-Maulschlüssel  
nach DIN 3113/ISO 3318, Form A,  
Ringende 15° gekröpft, verchromt**

Combination Wrenches,  
DIN 3113/ISO 3318,  
Form A, 15° offset, chrome plated

Clés mixtes, DIN 3113/ISO 3318,  
Forme A, inclinées à 15°, chromées

Llaves combinadas, DIN 3113/ISO  
3318, forma A, cromadas, con 15°  
inclinacion de la llave estriada

Bestell-Nr. Part No. Référence No. Referencia No.		Länge Length Longueur Largo	Gewicht Weight Poids Peso
	mm	mm	g
00 1000 0006	6	128	23
00 1000 0007	7	138	24
00 1000 0008	8	148	31
00 1000 0009	9	160	41
00 1000 0010	10	167	51
00 1000 0011	11	186	61
00 1000 0012	12	196	77
00 1000 0013	13	205	96
00 1000 0014	14	223	116
00 1000 0015	15	233	131
00 1000 0016	16	243	159
00 1000 0017	17	262	180
00 1000 0018	18	272	209
00 1000 0019	19	281	228
00 1000 0020	20	290	257
00 1000 0021	21	301	280
00 1000 0022	22	319	342
00 1000 0023	23	329	338
00 1000 0024	24	339	410
00 1000 0025	25	358	485
00 1000 0026	26	358	485
00 1000 0027	27	388	600
00 1000 0028	28	396	730
00 1000 0029	29	404	730
00 1000 0030	30	404	730
00 1000 0032	32	425	958
00 1000 0036	36	470	1100
00 1000 0041	41	505	1290
00 1000 0046	46	520	1800
00 1000 0050	50	560	2200
00 1000 0055	55	610	2800
00 1000 0060	60	660	3600



**Sätze**

Sets

Jeux

Juegos

Bestell-Nr. Part No. Référence No. Referencia No.	Zusammenstellung Contents Composition Composición	Gewicht Weight Poids Peso
		g
00 1000 7410	1000/10 T 8, 9, 10, 11, 12, 13, 14, 16, 17, 19	1330
00 1000 7112	1000/12 8, 9, 10, 11, 12, 13, 14, 15, 17, 19, 21, 22	1650
00 1000 7412	1000/12 T 6, 8, 9, 10, 11, 13, 14, 15, 17, 19, 21, 22	1700
00 1000 7414	1000/14 T 7, 8, 9, 10, 11, 12, 13, 14, 15, 17, 19, 21, 22, 24	2190
00 1000 7116	1000/16 8, 9, 10, 11, 12, 13, 14, 15, 17, 19, 21, 22, 24 27, 30, 32	4350
00 1000 7417	1000/17 6, 7, 8, 9, 10, 11, 12, 13, 14, 15, 16, 17, 18, 19, 20, 21, 22	2350



# SCHRAUBENSCHLÜSSEL, SPEZIALKNARREN

WRENCHES, SPECIAL RATCHETS

CLÉS DE SERRAGE, CLÉS À CLIQUETS

LLAVES, CHICHARRAS ESPECIALES

## 1005



### Ring-Maulschlüssel mit Freilaufsystem, gerade, verchromt

Clés à roue libre, chromées

Llaves de rueda libre, cromadas

Free Wheeling Wrenches, straight, chrome plated

Bestell-Nr. Part No. Référence No. Referencia No.		Länge Length Longueur Largo	Gewicht Weight Poids Peso
	mm	mm	g
00 1005 0008	8	145	42
00 1005 0009	9	152	46
00 1005 0010	10	165	58
00 1005 0011	11	171	72
00 1005 0012	12	177	79
00 1005 0013	13	184	90
00 1005 0014	14	197	112
00 1005 0015	15	203	130
00 1005 0016	16	211	147
00 1005 0017	17	230	176
00 1005 0018	18	242	195
00 1005 0019	19	253	226

### Satz

Jeu

Set

Juego

Bestell-Nr. Part No. Référence No. Referencia No.	Zusammenstellung Contents Composition Composición	Gewicht Weight Poids Peso
		g
00 1005 7410	1005/10 KT 8, 9, 10, 11, 13, 14, 16, 17, 18, 19	1350

### Artikel-Nr.

Part No.  
Référence No.  
Referencia No.

<b>1810</b>	Hakenschlüssel nach DIN 1810 Hook Wrenches Clés à ergot Llaves de gancho
<b>2300</b>	Schlag-Maulschlüssel nach DIN 133 Open End Wrenches Clés à fourche à frapper Llaves de boca de golpe
<b>2400</b>	Schlag-Ringschlüssel nach DIN 7444 Box Wrenches Clés polygonales à frapper Llaves de estrella de golpe

Auf Anfrage / On request / Sur demande / A petición

**Doppelsteckschlüssel  
nach DIN 896 B/ISO 2236,  
aus Rohr, verchromt**

Box Wrenches,  
DIN 896 B/ISO 2236, tubular,  
chrome plated

Clés à tube, DIN 896 B/ISO 2236,  
en tube acier, chromées

Llaves de tubo,  
DIN 896 B/ISO 2236, de acero,  
cromadas

**3070**



Bestell-Nr. Part No. Référence No. Referencia No.		Länge Length Longueur Largo	Gewicht Weight Poids Peso
	mm	mm	g
00 3070 0607	6 x 7	110	40
00 3070 0809	8 x 9	110	40
00 3070 1011	10 x 11	120	65
00 3070 1213	12 x 13	140	95
00 3070 1415	14 x 15	140	155
00 3070 1617	16 x 17	150	155
00 3070 1719	17 x 19	170	200
00 3070 1819	18 x 19	170	200
00 3070 2022	20 x 22	170	220
00 3070 2123	21 x 23	170	300
00 3070 2426	24 x 26	190	370
00 3070 2427	24 x 27	190	370
00 3070 3032	30 x 32	210	470
00 3070 3236	32 x 36	230	670
00 3070 3641	36 x 41	230	1000

**Sätze**

Jeux

Sets

Juegos

Bestell-Nr. Part No. Référence No. Referencia No.	Zusammenstellung Contents Composition Composición	Gewicht Weight Poids Peso
		g
00 3070 7107	3070/7 8 x 9, 10 x 11, 12 x 13, 14 x 15, 16 x 17, 18 x 19, 20 x 22	720
00 3070 7111	3070/11 6 x 7, 8 x 9, 10 x 11, 12 x 13, 14 x 15, 16 x 17, 18 x 19, 20 x 22, 21 x 23, 24 x 27, 30 x 32	1580

**Drehstifte für 3070**

Broches pour 3070

Tommy Bars for 3070

Manerales para 3070

Bestell-Nr. Part No. Référence No. Referencia No.		Länge Length Longueur Largo	Gewicht Weight Poids Peso
	mm	mm	g
00 3075 0614	6 x 7 – 14 x 15	250	250
00 3075 1641	16 x 17 – 36 x 41	250	250

## SCHRAUBENSCHLÜSSEL, SPEZIALKNARREN

WRENCHES, SPECIAL RATCHETS

CLÉS DE SERRAGE, CLÉS À CLIQUETS

LLAVES, CHICHARRAS ESPECIALES

# 3125



### Spezialnarre (DBP) mit auswechselbaren Sechskanteinsätzen, verchromt

Special ratchets, with interchangeable hex. inserts, chrome plated

Clés à cliquets, embout hexagonal interchangeable, chromées

Chicharras especiales, con vasos intercambiables hexagonales, cromadas

Bestell-Nr. Part No. Référence No. Referencia No.	 mm	Größe Size Dimension Tamaño	Länge Length Longueur Largo	Gewicht Weight Poids Peso
00 3125 0607	7	1	150	70
00 3125 0608	8	1	150	70
00 3125 0609	9	1	150	70
00 3125 0610	10	2	180	110
00 3125 0611	11	2	180	110
00 3125 0612	12	3	200	130
00 3125 0613	13	3	200	130
00 3125 0614	14	4	230	195
00 3125 0615	15	4	230	195
00 3125 0616	16	5	280	360
00 3125 0617	17	5	280	360
00 3125 0618	18	5	280	360
00 3125 0619	19	5	280	360
00 3125 0621	21	6	300	510
00 3125 0622	22	6	300	510

### Spezialnarre (DBP) mit auswechselbaren Vierkanteinsätzen, CrV-Stahl, verchromt

Special ratchets, with interchangeable square inserts, chrome plated

Clés à cliquets, embout carré femelle interchangeable, chromées

Chicharras especiales, con vasos intercambiables cuadrados, cromadas

Bestell-Nr. Part No. Référence No. Referencia No.	 mm	Größe Size Dimension Tamaño	Länge Length Longueur Largo	Gewicht Weight Poids Peso
00 3125 0406	6	1	150	70
00 3125 0407	7	1	150	70
00 3125 0408	8	2	180	110
00 3125 0409	9	2	180	110
00 3125 0410	10	3	200	130
00 3125 0411	11	3	200	130
00 3125 0412	12	4	230	195
00 3125 0413	13	4	230	195
00 3125 0414	14	5	280	360
00 3125 0415	15	5	280	360
00 3125 0416	16	6	300	510
00 3125 0417	17	6	300	510
00 3125 0418	18	6	300	510
00 3125 0419	19	6	300	510

**Sechskanteinsätze für Nr. 3125, brüniert**

Inserts, hexagon for No. 3125, gun metal finish

Douilles, hexagonal pour No. 3125, brunies

Vasos, hexagonales para No. 3125, pavonados

Bestell-Nr. Part No. Référence No. Referencia No.		Größe Size Dimension Tamaño	Länge Length Longueur Largo	Gewicht Weight Poids Peso	S-Ring S-Ring Anneau Anillos
	mm		mm	g	
00 3127 0607	7	1	12	9	A 14 x 1
00 3127 0608	8	1	12	9	A 14 x 1
00 3127 0609	9	1	12	9	A 14 x 1
00 3127 0610	10	2	13	12	A 14 x 1
00 3127 0611	11	2	13	12	A 16 x 1
00 3127 0612	12	3	14	16	A 16 x 1
00 3127 0613	13	3	14	16	A 19 x 2
00 3127 0614	14	4	16	27	A 19 x 2
00 3127 0615	15	4	16	27	A 23 x 1,2
00 3127 0616	16	5	20	55	A 23 x 1,2
00 3127 0617	17	5	20	55	A 29 x 1,5
00 3127 0618	18	5	20	55	A 29 x 1,5
00 3127 0619	19	5	20	55	A 29 x 1,5
00 3127 0621	21	6	23	70	A 33 x 1,5
00 3127 0622	22	6	23	70	A 33 x 1,5



**Vierkanteinsätze für Nr. 3125, brüniert**

Inserts, square for No. 3125, gun metal finish

Douilles, carré femelle pour No. 3125, brunies

Vasos, cuadrados para No. 3125, pavonados

Bestell-Nr. Part No. Référence No. Referencia No.		Größe Size Dimension Tamaño	Länge Length Longueur Largo	Gewicht Weight Poids Peso	S-Ring S-Ring Anneau Anillos
	mm		mm	g	
00 3127 0406	6	1	12	9	A 14 x 1
00 3127 0407	7	1	12	9	A 14 x 1
00 3127 0408	8	1	12	9	A 16 x 1
00 3127 0409	9	3	13	12	A 16 x 1
00 3127 0410	10	3	14	16	A 19 x 1,2
00 3127 0411	11	3	14	16	A 19 x 1,2
00 3127 0412	12	4	16	27	A 23 x 1,2
00 3127 0413	13	4	16	27	A 23 x 1,2
00 3127 0414	14	5	20	55	A 29 x 1,5
00 3127 0415	15	5	20	55	A 29 x 1,5
00 3127 0416	16	5	20	55	A 29 x 1,5
00 3127 0417	17	6	23	70	A 33 x 1,5
00 3127 0418	18	6	23	70	A 33 x 1,5
00 3127 0419	19	6	23	70	A 33 x 1,5



# SCHRAUBENSCHLÜSSEL, SPEZIALKNARREN

WRENCHES, SPECIAL RATCHETS

CLÉS DE SERRAGE, CLÉS À CLIQUETS

LLAVES, CHICHARRAS ESPECIALES

## 3126



### Spezialnarre (DBP) für Überwurfmutter, mit auswechselbaren Sechskanteinsätzen, brüniert, ab SW 21 Zwölfkant

Special ratchets, with interchangeable hex. inserts, gun metal finish, from 21 mm only bihexagon

Cliquets spéciaux, pour tuyauteurs 6 pans, brunis, à partir de 21 mm seulement 12 pans

Chicharras especiales, con vasos intercambiables hex., pavonadas, a partir de 21 mm solamente doble hex.

Bestell-Nr. Part No. Référence No. Referencia No.	Größe Size Dimension Tamaño	Länge Length Longueur Largo	Gewicht Weight Poids Peso
	mm	mm	g
00 3126 0008	8	1	175
00 3126 0009	9	1	175
00 3126 0010	10	1	175
00 3126 0011	11	1	175
00 3126 0012	12	2	245
00 3126 0013	13	2	245
00 3126 0014	14	2	245
00 3126 0015	15	3	435
00 3126 0016	16	3	435
00 3126 0017	17	3	435
00 3126 0018	18	3	435
00 3126 0019	19	3	435

00 3126 0021	21	4	1100
00 3126 0022	22	4	1100
00 3126 0024	24	4	1100
00 3126 0027	27	4	1100

## 3128E



### Einsätze für Nr. 3126, brüniert

Inserts for No. 3126, gun metal finish

Douilles pour No. 3126, brunies

Vasos para No. 3126, pavonados

Bestell-Nr. Part No. Référence No. Referencia No.	Größe Size Dimension Tamaño	Länge Length Longueur Largo	Gewicht Weight Poids Peso	S-Ring S-Ring Anneau Anillos
	mm	mm	g	
00 3128 0008	8	1	20	H 20
00 3128 0009	9	1	20	H 20
00 3128 0010	10	1	20	H 20
00 3128 0011	11	1	20	H 20
00 3128 0012	12	2	25	H 23
00 3128 0013	13	2	25	H 23
00 3128 0014	14	2	25	H 23
00 3128 0015	15	3	42	H 30
00 3128 0016	16	3	42	H 30
00 3128 0017	17	3	42	H 30
00 3128 0018	18	3	42	H 30
00 3128 0019	19	3	42	H 30

00 3128 0021	21	4	80	H 45
00 3128 0022	22	4	80	H 45
00 3128 0024	24	4	80	H 45
00 3128 0027	27	4	80	H 45

**Knarren-Ringschlüssel  
für Außentorxschrauben,  
umschaltbar**

Double Box Wrenches – Ratcheting,  
for screws with outside torx profile,  
reversible

Clés à cliquets, pour vis torx à  
empreinte mâle, réversible

Llaves de estrella con trinquete,  
para tornillos torx exteriores,  
reversibles

Bestell-Nr. Part No. Référence No. Referencia No.		Länge Length Longueur Largo	Gewicht Weight Poids Peso
		mm	g
00 3129 0406	E 4 x E 6	108	51
00 3129 0608	E 6 x E 8	108	51
00 3129 1012	E 10 x E 12	134	76

3129



**Knarren-Ringschlüssel  
für Außentorxschrauben  
abgewinkelt, umschaltbar**

Double Box Wrenches – Ratcheting,  
offset, for screws with outside torx  
profile, reversible

Clés à cliquets, inclinées, pour vis  
torx à empreinte mâle, réversible

Llaves de estrella con trinquete,  
acodada, para tornillos torx  
exteriores, reversibles

Bestell-Nr. Part No. Référence No. Referencia No.		Länge Length Longueur Largo	Gewicht Weight Poids Peso
		mm	g
00 3132 0406	E 4 x E 6	104	51
00 3132 0608	E 6 x E 8	104	51
00 3132 1012	E 10 x E 12	128	76
00 3132 1416	E 14 x E 16	139	89

3132



**STECKSCHLÜSSEL, WINKELSCHRAUB**

SOCKET SPANNERS, L-KEYS

CLÉS À DOUILLES, CLÉS

LLAVES, LLAVES HEXAGONALES

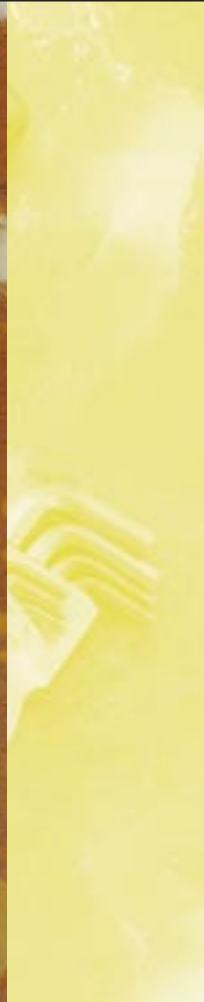

260

D

PRODUKTBESCHREIBUNG

GB

PRODUCT DISCRPTION  
OPERATING INSTRUCTIONS

US

SOCKET SPANNERS, L-KEYS

E

DESCRIPCIÓN DE LOS  
PRODUCTOS

LLAVES DE TUBO, LLAVES ALLEN

Llaves de tubo con mango, Llaves "L" hexagonales y torx, formas de bola, y un diferente surtido.

Este programa ofrece un suplemento óptimo de llaves para apretar tuercas y llaves de tubo.

Estas herramientas están diseñadas para uso manual, cumplen las normas DIN/ISO, apropiadas para tornillos con exterior hexagonal, e interior hexagonal, interior XZN, perfiles exteriores torx, y perfiles interiores torx.

Las versiones de las cabezas de bola, son aplicables donde el posicionamiento axial hacia el tornillo no es posible, por su utilidad están fabricadas en ángulo.

SOCKET SPANNERS WITH HANDLE, L-KEYS WITH HEXAGON AND TORX, BALL FORM AND IN DIFFERENT SET ARRANGEMENTS

This programme offers an optimum supplement where spanners and socket spanners cannot be applied due to obtuse angels. These tools are designed for hand use and conform to respective DIN /ISO norms. Suitable for bolts with outer hexagon, inner hexagon, XZN profile, outer torx profile, inner torx profile. Ball head versions are applicable where an axial approach to the bolt is not possible but has to made at certain angle.

F

DESCRIPTIF TECHNIQUE  
CONSELS D'UTILISATION

CLEFS À DOUILLES, CLEFS À RENVOI D'ANGLE

Clefs à douilles avec manche, clefs à renvoi d'angle à six pans et torx aussi avec forme sphérique et dans des jeux composés différemment.

Ce programme offre un complément parfait dans les cas ou l'on ne peut utiliser ni un tournevis ni une clef à douille pour réaliser un vissage exact.

Ces instruments sont faits pour la manutention et correspondent aux normes respectives DIN/ISO. On peut visser des boulons à six pans extérieurs ou six pans intérieurs multi-pans intérieurs, torx profil intérieur torx profil extérieur.

Les modèles avec forme sphérique sont à utiliser la où on ne peut atteindre la vis en axial mais seulement sous un certain angle.

**STECKSCHLÜSSEL MIT GRIFF, WINKELSCHRAUBENDREHER MIT SECHSKANT UND TORX, AUCH MIT KUGELFORM UND IN VERSCHIEDENEN SATZZUSAMMENSTELLUNGEN**

**Dieses Programm bietet die optimale Ergänzung überall dort, wo man mit einem Schraubenschlüssel oder Steckschlüssel nicht ansetzen bzw. keine exakte Verschraubung durchführen kann.**

**Diese Arbeitsmittel sind für die Handbetätigung geeignet und entsprechen der jeweiligen DIN/ISO-Norm.**

**Verschraubt werden können Schrauben mit Außensechskant, Innensechskant, Innenvielzahn, Torx-Innenprofil, Torx-Außenprofil.**

**Ausführungen mit Kugelform sind dort einsetzbar, wo man nicht axial zur Schraube, sondern nur unter einem gewissen Winkel ansetzen kann.**

**ENDREHER**

**MÂLES**

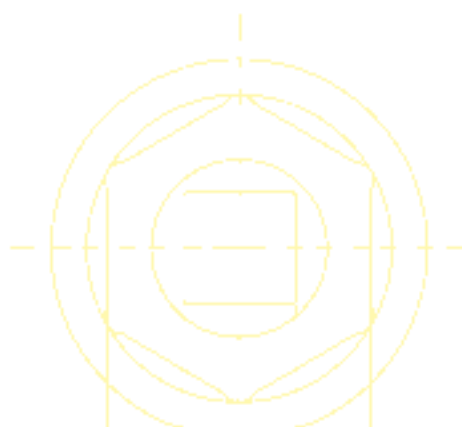

11.9.40-43HRC

## STECKSCHLÜSSEL, WINKELSCHRAUBENDREHER

SOCKET SPANNERS, L-KEYS

CLÉS À DOUILLES, CLÉS MÂLES

LLAVES, LLAVES HEXAGONALES

### 3030



### Sechskant-Steckschlüssel mit Griff, DIN 3125/ISO 2725, verchromt

Hex Nut-Drivers, long pattern, DIN 3125/ISO 2725, chrome plated

Clés à douille emmanchées, 6 pans, modèle long, DIN 3125/ISO 2725, chromées

Llaves hexagonales con mango, tipo largo, DIN 3125/ISO 2725, cromados

Bestell-Nr. Part No. Référence No. Referencia No.		Länge Length Longueur Largo	Gewicht Weight Poids Peso
	mm	mm	g
00 3030 0003	3	250	70
00 3030 0035	3,5	250	70
00 3030 0004	4	250	70
00 3030 0045	4,5	250	75
00 3030 0005	5	250	75
00 3030 0055	5,5	250	87
00 3030 0006	6	250	90
00 3030 0007	7	250	100
00 3030 0008	8	250	120
00 3030 0009	9	250	125
00 3030 0010	10	250	125
00 3030 0011	11	250	165
00 3030 0012	12	250	165
00 3030 0013	13	250	168
00 3030 0014	14	250	190
00 3030 0015	15	250	190
00 3030 0016	16	250	190
00 3030 0017	17	250	200

### 3030K



### Sechskant-Steckschlüssel mit Griff, kurz, DIN 3125/ISO 2725, verchromt

Hex Nut-Drivers, short pattern, DIN 3125/ISO 2725, chrome plated

Clés à douille emmanchées, DIN 3125/ISO 2725, 6 pans modèle court, chromées

Llaves hexagonales, con mango, tipo corto, DIN 3125/ISO 2725, cromados

Bestell-Nr. Part No. Référence No. Referencia No.		Länge Length Longueur Largo	Gewicht Weight Poids Peso
	mm	mm	g
00 3030 0203	3	100	45
00 3030 0204	4	100	52
00 3030 0205	5	100	60
00 3030 0206	6	150	80
00 3030 0207	7	150	87
00 3030 0208	8	200	90
00 3030 0210	10	150	94
00 3030 0213	13	200	139

### Sechskant-Steckschlüssel mit T-Griff, verchromt

Hex Nut-Drivers with T-handle, chrome plated

Clés à douille, 6 pans, manches en T, chromées

Llaves hexagonales con mango en T, cromados

Bestell-Nr. Part No. Référence No. Referencia No.		Länge Length Longueur Largo	Gewicht Weight Poids Peso
	mm	mm	g
00 3036 0004	4	230	80
00 3036 0045	4,5	230	84
00 3036 0005	5	230	91
00 3036 0055	5,5	230	99
00 3036 0006	6	230	108
00 3036 0008	8	230	117
00 3036 0009	9	230	119
00 3036 0010	10	230	147
00 3036 0011	11	230	149
00 3036 0012	12	230	150
00 3036 0013	13	230	184
00 3036 0014	14	230	196

# 3036



### Schraubendreher mit T-Griff für Innentorxschrauben, verchromt

Screwdrivers with T-handle for inner torx screws, chrome plated

Tournevis à poignée en T pour vis torx à empreinte femelle, chromé

Destornilladores con mango en T para tornillos torx interiores, cromados

Bestell-Nr. Part No. Référence No. Referencia No.		Länge Length Longueur Largo	Gewicht Weight Poids Peso
		mm	g
00 3078 0006	TX 6	100	70
00 3078 0007	TX 7	100	70
00 3078 0008	TX 8	100	70
00 3078 0009	TX 9	100	70
00 3078 0010	TX 10	100	70
00 3078 0015	TX 15	100	70
00 3078 0020	TX 20	125	90
00 3078 0025	TX 25	125	90
00 3078 0027	TX 27	125	90
00 3078 0030	TX 30	125	90
00 3078 0040	TX 40	125	90
00 3078 0045	TX 45	150	110
00 3078 0050	TX 50	150	110
00 3078 0055	TX 55	150	110
00 3078 0060	TX 60	150	110

# 3078



## STECKSCHLÜSSEL, WINKELSCHRAUBENDREHER

SOCKET SPANNERS, L-KEYS

CLÉS À DOUILLES, CLÉS MÂLES

LLAVES, LLAVES HEXAGONALES

### 3178



#### Steckschlüssel mit T-Griff für Außentorxschrauben, verchromt

Nut-Drivers with T-handle, for outside torx screws, chrome plated

Clés à douille, manches en T, pour vis torx à empreinte mâle, chromé

Llaves de tubo con mango en T, para tornillos torx exteriores, cromados

Bestell-Nr. Part No. Référence No. Referencia No.		Länge Length Longueur Largo	Gewicht Weight Poids Peso
		mm	g
00 3178 0006	E 6	230	120
00 3178 0007	E 7	230	120
00 3178 0008	E 8	230	130
00 3178 0010	E 10	230	140
00 3178 0012	E 12	230	150
00 3178 0014	E 14	230	170
00 3178 0016	E 16	230	180
00 3178 0310	E 10	300	210

### 3045



#### Winkelschraubendreher für XZN-Schrauben, brüniert

Head Wrenches for XZN-screws, gun metal finish

Clés mâles empreinte XZN, brunies

Llaves multi-angulares para tornillos XZN, pavonadas

Bestell-Nr. Part No. Référence No. Referencia No.		Länge Length Longueur Largo	Gewicht Weight Poids Peso
		mm	g
00 3045 0005	M 5	72	15
00 3045 0006	M 6	80	20
00 3045 0008	M 8	90	40
00 3045 0010	M 10	100	90
00 3045 0012	M 12	112	120
00 3045 0014	M 14	125	180
00 3045 0016	M 16	140	200
00 3045 0018	M 18	140	370

#### Satz 5-tlg., im Handklapphalter, brüniert

Set of 5 pcs., with Holder, gun metal finish

Jeu de 5 clés XZN avec support, bruni

Juego de 5 pzas. XZN con soporte, pavonadas

Bestell-Nr. Part No. Référence No. Referencia No.	Zusammenstellung Contents Composition Composición	Gewicht Weight Poids Peso
		g
00 3045 7605	3045/5H M 5 - 6 - 8 - 10 - 12	450

**Winkelschraubendreher  
nach DIN 911/ISO 2936,  
für Innensechskantschrauben,  
brüniert**

Hex Head Wrenches,  
DIN 911/ISO 2936, gun metal finish

Clés mâles, pour vis 6 pans creux,  
DIN 911/ISO 2936, brunies

LLaves hexagonales,  
DIN 911/ISO 2936, pavonadas

**3050**

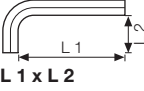

Bestell-Nr. Part No. Référence No. Referencia No.			Gewicht Weight Poids Peso
00 3050 0015	1,5	45 x 14	1
00 3050 0002	2	50 x 16	2
00 3050 0025	2,5	56 x 18	4
00 3050 0003	3	63 x 20	5
00 3050 0004	4	70 x 25	10
00 3050 0005	5	80 x 28	18
00 3050 0006	6	90 x 32	30
00 3050 0007	7	95 x 34	43
00 3050 0008	8	100 x 36	59
00 3050 0009	9	105 x 39	79
00 3050 0010	10	112 x 40	103
00 3050 0011	11	119 x 42	131
00 3050 0012	12	125 x 45	160
00 3050 0013	13	132 x 50	215
00 3050 0014	14	140 x 55	260
00 3050 0150	15	140 x 55	290
00 3050 0016	16	160 x 60	400
00 3050 0017	17	160 x 63	430
00 3050 0018	18	170 x 65	510
00 3050 0019	19	180 x 70	620
00 3050 0020	20	180 x 70	650
00 3050 0022	22	200 x 80	950
00 3050 0024	24	224 x 90	1250

**Winkelschraubendreher im Satz  
mit schlagfester Kunststoffbox,  
DIN 911/ISO 2936, Brüniert**

Hex Head Wrenches Set in box,  
DIN 911/ISO 2936, gun metal finish

Jeu clés mâles, DIN 911/ISO 2936,  
en boîte plastique, brunies

Juego de llaves hex.,  
DIN 911/ISO 2936, en cajita de  
plástico, pavonadas

**3050/8**



Bestell-Nr. Part No. Référence No. Referencia No.	Zusammenstellung Contents Composition Composición	Gewicht Weight Poids Peso
00 3050 0000	2 - 2,5 - 3 - 4 - 5 - 6 - 8 - 10	290

## STECKSCHLÜSSEL, WINKELSCHRAUBENDREHER

SOCKET SPANNERS, L-KEYS

CLÉS À DOUILLES, CLÉS MÂLES

LLAVES, LLAVES HEXAGONALES

# 3051



### Winkelschraubendreher nach DIN 911 L/ISO 2936, brüniert

Hex Head Wrenches, long pattern, DIN 911 L/ISO 2936, gun metal finish

Clés mâles, modèle long, DIN 911 L/ISO 2936, bruniées

LLaves hexagonales, tipo largo, DIN 911 L/ISO 2936, pavonadas

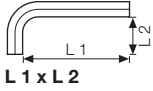
Bestell-Nr. Part No. Référence No. Referencia No.			Gewicht Weight Poids Peso
	mm	mm	g
00 3051 0015	1,5	90 x 14	2
00 3051 0002	2	100 x 16	4
00 3051 0025	2,5	112 x 18	6
00 3051 0003	3	126 x 20	9
00 3051 0004	4	140 x 25	19
00 3051 0005	5	160 x 28	33
00 3051 0006	6	180 x 32	54
00 3051 0007	7	200 x 36	80
00 3051 0008	8	200 x 36	105
00 3051 0009	9	224 x 40	148
00 3051 0010	10	224 x 40	185
00 3051 0011	11	250 x 45	247
00 3051 0012	12	250 x 45	295
00 3051 0013	13	280 x 55	370
00 3051 0014	14	280 x 55	460
00 3051 0017	17	320 x 63	750
00 3051 0019	19	360 x 70	1100
00 3051 0022	22	400 x 80	1650
00 3051 0024	24	448 x 90	2140

# 3051/9H



### Satz in Kunststoffclip, DIN 911 L/ISO 2936, brüniert

Set with holder, DIN 911 L/ISO 2936, gun metal finish

Jeu avec support, DIN 911 L/ISO 2936, bruni

Juego con soporte, DIN 911 L/ISO 2936, pavonadas

Bestell-Nr. Part No. Référence No. Referencia No.	Zusammenstellung Contents Composition Composición	Gewicht Weight Poids Peso
		g
00 3051 0000	1,5 - 2 - 2,5 - 3 - 4 - 5 - 6 - 8 - 10	440

**Winkelschraubendreher mit Kugelkopf, lang, brüniert**

Hex Head Wrenches with ball hex, long pattern, gun metal finish

Clés mâles coudées a têtes sphériques, modèle long, brunies

Llaves hexagonales con punta esférica, tipo largo, pavonadas

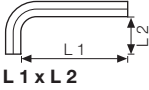
Bestell-Nr. Part No. Référence No. Referencia No.			Gewicht Weight Poids Peso
	mm	mm	g
00 3052 0015	1,5	90 x 14	2
00 3052 0002	2	100 x 16	4
00 3052 0025	2,5	112 x 18	6
00 3052 0003	3	126 x 20	9
00 3052 0004	4	140 x 25	19
00 3052 0005	5	160 x 28	33
00 3052 0006	6	180 x 32	54
00 3052 0007	7	200 x 36	80
00 3052 0008	8	200 x 36	105
00 3052 0010	10	224 x 40	148
00 3052 0012	12	250 x 45	295

3052



**Satz in Kunststoffclip, brüniert**

Set with holder, gun metal finish

Jeu avec support, bruni

Juego con soporte, pavonadas

Bestell-Nr. Part No. Référence No. Referencia No.	Zusammenstellung Contents Composition Composición	Gewicht Weight Poids Peso
00 3052 0000	1,5 - 2 - 2,5 - 3 - 4 - 5 - 6 - 8 - 10	g 425

3052/9H



## STECKSCHLÜSSEL, WINKELSCHRAUBENDREHER

SOCKET SPANNERS, L-KEYS

CLÉS À DOUILLES, CLÉS MÂLES

LLAVES, LLAVES HEXAGONALES

### 3053



#### Winkelschraubendreher mit Kugelkopf für Innentorx-schrauben, brüniert

Head Wrenches for inner torx screws, with ball end, gun metal finish

Clés mâles à têtes sphérique, coudées, pour vis torx à empreinte femelle, bruniées

Llaves con punta esférica, para tornillos torx interiores, con punta esférica, pavonadas

#### Bestell-Nr.

Part No.  
Référence No.  
Referencia No.

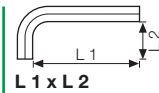

L 1 x L 2

mm

#### Gewicht

Weight  
Poids  
Peso

g

00 3053 0009	TX 9	64 x 16	4
00 3053 0010	TX 10	73 x 17	5
00 3053 0015	TX 15	83 x 17	7
00 3053 0020	TX 20	94 x 18	10
00 3053 0025	TX 25	96 x 18	14
00 3053 0027	TX 27	106 x 20	22
00 3053 0030	TX 30	119 x 24	30
00 3053 0040	TX 40	132 x 26	45
00 3053 0045	TX 45	137 x 29	64

### 3053/8H



#### Satz in Kunststoffclip, brüniert

Set with holder, gun metal finish

Jeu avec support, bruni

Juego con soporte, pavonadas

#### Bestell-Nr.

Part No.  
Référence No.  
Referencia No.

#### Zusammenstellung

Contents  
Composition  
Composición

#### Gewicht

Weight  
Poids  
Peso

g

00 3053 0000	TX 9, TX 10, TX 15, TX 20, TX 25, TX 27, TX 30, TX 40	440
--------------	---	-----

**Winkelschraubendreher für Innen-Torxschrauben, brüniert**

Head Wrenches for inner Torx screws, gun metal finish

Clés mâles coudées pour vis Torx à empreinte femelle, brunis

Llaves para tornillos Torx interiores, pavonadas

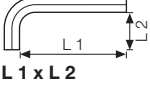
Bestell-Nr. Part No. Référence No. Referencia No.			Gewicht Weight Poids Peso
		mm	g
00 3060 0009	TX 9	48 x 16	3
00 3060 0010	TX 10	51 x 16	4
00 3060 0015	TX 15	54 x 18	5
00 3060 0020	TX 20	57 x 19	7
00 3060 0025	TX 25	60 x 20	10
00 3060 0027	TX 27	64 x 21	15
00 3060 0030	TX 30	70 x 24	20
00 3060 0040	TX 40	76 x 26	30
00 3060 0045	TX 45	83 x 29	40
00 3060 0050	TX 50	95 x 32	60

**3060**



Mit Zentrierbohrung auf Anfrage  
With hollow point on request  
Avec trou sur demande  
Con agujero a petición

**Satz in Kunststoffclip, brüniert**

Set with holder, gun metal finish

Jeu avec support, bruni

Juego con soporte, pavonadas

Bestell-Nr. Part No. Référence No. Referencia No.	Zusammenstellung Contents Composition Composición	Gewicht Weight Poids Peso
00 3060 0000	TX 9, TX 10, TX 15, TX 20, TX 25, TX 27, TX 30, TX 40	g 240

**3060/8H**



**Satz 8-tlg., im Handklapphalter, brüniert**

Set of 8 pcs., with holder, gun metal finish

Jeu de 8 clés, avec support, bruni

Juego pzas. con soporte, 8 pcs., pavonadas

Bestell-Nr. Part No. Référence No. Referencia No.	Zusammenstellung Contents Composition Composición	Gewicht Weight Poids Peso
00 3060 7608	TX 9, TX 10, TX 15, TX 20, TX 25, TX 27, TX 30, TX 40	g 240

**3060/K**



**SCHRAUBENDREHER**

SCREWDRIVERS

TOURNEVIS

DESTORNILLADORES



1, verg. 40-43HRC

## D PRODUKTBESCHREIBUNG

### SCHRAUBENDREHER FÜR ALLE ANWENDUNGSFÄLLE, Z.B. SCHLITZ-, KREUZSCHLITZ- UND TORX-SCHRAUBEN, AUCH IN VDE-AUSFÜHRUNG

Das neue SALTUS-Schraubendreherprogramm besticht durch eine neuartige Kombination aus harten und weichen Oberflächen am ergonomisch optimalen Dreikantgriff.

Der Dreikantgriff bietet die ideale Kombination von Formschluss und Reibschluss. Die reibschlüssigen Flächen bestehen aus Hartmaterial. Damit wird eine deutliche Erhöhung der Reibung erreicht. Die Zonen für den Formschluss bestehen dagegen aus weicherem Material. Neben absolut sicheren und hohen Drehmomenten wird damit ein angenehmes Greifgefühl ohne die bislang üblichen Druckstellen erreicht.

Auffallend ist auch die allgemein kantlose Gestaltung des Griffes mit ergonomisch richtigem Übergang vom Griffhaupteckkörper zur gering dimensionierten Multifunktionszone und der ausgeprägten Abrutschkante für Kräfte in axialer Richtung. Das ermöglicht einen schnellen weichen Wechsel zwischen größeren und kleineren Drehmomenten und damit schnelleres Drehen.

Die Klingen der SALTUS-Schraubendreher bestehen aus hochlegiertem Spezialstahl mit brüniertes Klingenspitze, der Schaft ist matt verchromt oder isoliert.

VDE-Schraubendreher nach DIN EN 60900 stehen unter der ständigen Kontrolle der VDE-Prüfstelle. Klinge, Isolierung und Griff sind unlösbar miteinander verbunden. Sie können in Spannungsbereichen bis AC 1000 Volt und DC 1500 Volt zum Arbeiten an unter Spannung stehenden Teilen eingesetzt werden. SALTUS-VDE-Schraubendreher werden Stück für Stück im Wasserbad mit einer Prüfspannung von 10.000 Volt auf ihre Sicherheit geprüft.

**GB** PRODUCT DESCRIPTION  
OPERATING INSTRUCTIONS

**US** SCREWDRIVERS FOR ALL APPLICATIONS, E.G. SLOTTED, PHILLIPS AND TORX SREWS, OR IN VDE-VERSION.

The new SALTUS screwdriver line features an innovative combination of hard and soft surfaces with its ergonomically formed three-point handle.

The three-point handle offers an ideal combination of positive contact and frictional contact. The frictional surfaces consist of hard material which increases friction significantly. The zones for positive contact are made of softer material. Thus, secure and high torque is achieved, ensuring a comfortable grip feeling and avoiding the usual pressure marks.

SALTUS-screwdrivers have an edge-free handle design with ergonomically correct transition from the handle's main body to its smaller multi-function zone, coupled with a slide-stop for axial forces. This allows a fast soft change between high and low torque and therefore quicker turning.

The blades of all SALTUS-screwdrivers are made of high-alloyed special steel with black tips, the shaft is either matt-chromed or industrial finish.

VDE screwdrivers according to DIN EN 60900 are permanently controlled by the VDE's testing institute. Blade, isolation and handle are connected inseparably. They are usable on live-wire parts up to a voltage of 1000 volt AC or 1500 volt DC. SALTUS-VDE-screwdrivers are individually tested for safety with a testing voltage of 10.000 volts in a water bath.

**F** DESCRIPTIF TECHNIQUE  
CONSELS D'UTILISATION

### LES TOURNEVIS

Tournevis pour toute utilisation, par exemple plat, cruciforme et torx ainsi qu'exécuti-on VDE.

Le nouveau programme tournevis SALTUS convaint par sa combinaison nouvelle de matériel de surface dur et mou au manche triangulaire ergonomique.

Le manche triangulaire se présente en une combinaison idéale de finition dans la forme et la friction. Les zones de grip sont en matériel dur ce qui permet une plus forte résistance au frottement. Les autres zones sont dans un matériel plus mou. En plus donc, d'un couple de serrage absolument sûr et élevé on obtient une grande puissance de confort qui protège la paume.

Remarquable aussi l'exécution arrondie de l'avant cylindrique avec une approche très rapide de la zone multifonctionnelle pour l'effort axial. Ceci rend possible un changement optimum entre des couples de serrage de puissance faible ou élevée et donc des vissages plus rapides.

Les lames de tournevis SALTUS sont faites dans un acier alloy spécial, la pointe brune est chromée mate ou isolée.

Les tournevis VDE DIN EN 60900 sont sous contrôles constants des laboratoires d'essai de VDE. La lame, l'isolation et le manche sont inséparablement liés. On peut les utiliser dans un corridor de tension de AC 1000 Volt et DC 1500 Volt et travailler avec des objets se trouvant sous tension. Les tournevis SALTUS VDE passent, pièce par pièce, des contrôles de sécurité dans un bain d'eau, sous des tensions de 10.000 Volt.

**E** DESCRIPCIÓN DE LOS PRODUCTOS

DESTORNILLADORES PARA TODAS LAS APLICACIONES, E.G. DENTADOS, PHILLIPS, TORX O EN VERSION - VDE

La nueva línea de destornilladores SALTUS, dispone de una combinación innovadora de superficies duras y blandas, que forman un mango de tres puntos, con importante mejora ergonómica.

El mango de tres puntas ofrece una combinación ideal de contacto positivo y contacto por fricción. Las caras de fricción consisten en material duro, el cual aumenta la fricción significativamente. Las zonas de contacto positivo, están hechas de un material más blando. De este modo, se consigue seguridad y potencia, asegurando una sensación de sujeción confortable y evitando las marcas usuales de la presión.

LOS DESTORNILLADORES SALTUS, tienen los mangos diseñados con el filo libre, tienen una transición ergonómicamente correcta, desde el cuerpo mayor del mango hasta la zona multifuncional más pequeña, acoplado con un antideslizamiento para fuerza axial. Esto permite un cambio rápido y suave, entre el alto y el bajo momento de fuerza y por lo tanto un torneado más rápido.

Las hojas de los destornilladores SALTUS, están fabricadas en una aleación especial de acero y puntas negras, las varillas pueden ser cromadas o pavonadas.

Los destornilladores VDE acordes con la norma DIN EN 60900 están permanentemente controlados por el test del instituto de VDE. La cuchilla y el mango están conectados inseparablemente. Pueden ser usados con corrientes de hasta un 1000 Volt. AC o 1500 Volt. DC. Los destornilladores VDE de SALTUS están comprobados individualmente por seguridad con un test de voltaje de 10.000 Volt en baños de agua.

# SCHRAUBENDREHER

SCREWDRIVERS

TOURNEVIS

DESTORNILLADORES

## 7000



### Werkstatt-Schraubendreher mit Sechskant, schwarze Spitze, nach DIN 5263/5264/ISO 2380

Engineer's screwdrivers with hexagon bolster, black tips, as per DIN 5263/5264/ISO 2380

Tournevis d'atelier, avec 6 pans, extrémité noire, selon DIN 5263/5264/ISO 2380

Destornilladores para taller, con hexágono, punta negra, según DIN 5263/5264/ISO 2380

Bestell-Nr. Part No. Référence No. Referencia No.	 a x b mm	Klingenlänge Blade Lame Hoja mm	Heftgröße Handle Manche Mango mm	Gewicht Weight Poids Peso g
00 7000 0100	1 x 5,5	100	100 x 28	57
00 7000 0200	1,2 x 6,5	125	110 x 31	88
00 7000 0300	1,2 x 8	150	125 x 36	139
00 7000 0400	1,6 x 10	175	125 x 36	164
00 7000 0500	2 x 12	200	125 x 36	232

## 7016



### Werkstatt-Schraubendreher ohne Sechskant, schwarze Spitze, nach DIN 5263/5264/ISO 2380

Engineer's screwdrivers without hexagon, black tips, as per DIN 5263/5264/ISO 2380

Tournevis d'atelier, extrémité noire, selon DIN 5263/5264/ISO 2380

Destornilladores para taller, punta negra, según DIN 5263/5264/ISO 2380

Bestell-Nr. Part No. Référence No. Referencia No.	 a x b mm	Klingenlänge Blade Lame Hoja mm	Heftgröße Handle Manche Mango mm	Gewicht Weight Poids Peso g
00 7016 0100	0,6 x 3,5	75	90 x 25	29
00 7016 0200	0,8 x 4	75	90 x 25	35
00 7016 0300	1 x 5,5	100	100 x 28	52
00 7016 0400	1,2 x 6,5	125	110 x 31	79
00 7016 0500	1,2 x 8	150	125 x 36	130
00 7016 0030	1 x 6	25	55 x 29	32

## 7026



### Elektriker-Schraubendreher, schwarze Spitze, nach DIN 5263/5264/ISO 2380

Electrician's screwdrivers, black tips, as per DIN 5263/5264/ISO 2380

Tournevis électricien, extrémité noire, selon DIN 5263/5264/ISO 2380

Destornilladores para electricista, punta negra, según DIN 5263/5264/ISO 2380

Bestell-Nr. Part No. Référence No. Referencia No.	 a x b mm	Klingenlänge Blade Lame Hoja mm	Heftgröße Handle Manche Mango mm	Gewicht Weight Poids Peso g
00 7026 0100	0,5 x 3,0	75	90 x 25	29
00 7026 0200	0,6 x 3,5	100	90 x 25	32
00 7026 0300	0,8 x 4	125	90 x 25	38
00 7026 0400	1 x 5,5	150	100 x 28	65

**Schraubendreher mit Sechskant,  
für Phillips-Schrauben,  
schwarze Spitze,  
nach DIN 5260/5261/ISO 8764**

Screwdrivers for Phillips screws with hexagon bolster, black tips, as per DIN 5260/5261/ISO 8764

Tournevis, avec 6 pans, extrémité noire, pour vis cruciforme Phillips selon DIN 5260/5261/ISO 8764

Destornilladores para tornillos Phillips con hexágono punta negra, según DIN 5260/5261/ISO 8764

Bestell-Nr. Part No. Référence No. Referencia No.		Klingenlänge	Heftgröße	Gewicht
		Blade Lame Hoja	Handle Manche Mango	Weight Poids Peso
		mm	mm	g
00 7040 0100	PH 1	80	100 x 28	49
00 7040 0200	PH 2	100	110 x 31	82
00 7040 0300	PH 3	150	125 x 36	152
00 7040 0400	PH 4	200	125 x 36	253

7040



**Schraubendreher, für Phillips-  
Schrauben, schwarze Spitze,  
nach DIN 5260/5261/5262**

Screwdrivers for Phillips screws, black tips, as per DIN 5260/5261/5262

Tournevis pour vis cruciforme Phillips, selon DIN 5260/5261/5262

Destornilladores para tornillos Phillips, punta negra, según DIN 5260/5261/5262

Bestell-Nr. Part No. Référence No. Referencia No.		Klingenlänge	Heftgröße	Gewicht
		Blade Lame Hoja	Handle Manche Mango	Weight Poids Peso
		mm	mm	g
00 7041 0000	PH 0	60	90 x 25	28
00 7041 0100	PH 1	80	100 x 28	48
00 7041 0200	PH 2	100	110 x 31	75
00 7041 0300	PH 3	150	125 x 36	142
00 7041 0020	PH 2	25	55 x 29	34

7041



# SCHRAUBENDREHER

SCREWDRIVERS

TOURNEVIS

DESTORNILLADORES

## 7050



### Schraubendreher für Pozidriv-Schrauben, schwarze Spitze, nach ISO 8764

Screwdrivers for Pozidriv screws, black tips, as per ISO 8764

Tournevis pour vis Pozidriv, extrémité noire, selon ISO 8764

Destornilladores para tornillos Pozidriv, punta negra, según ISO 8764

Bestell-Nr. Part No. Référence No. Referencia No.		Klingenlänge Blade Lame Hoja	Heftgröße Handle Manche Mango	Gewicht Weight Poids Peso
		mm	mm	g
00 7050 0000	PZ 0	60	90 x 25	28
00 7050 0100	PZ 1	80	100 x 28	48
00 7050 0200	PZ 2	100	110 x 31	75
00 7050 0300	PZ 3	150	25 x 36	142
00 7050 0020	PZ 2	25	55 x 29	34

## 7052



### Kugelkopf-Schraubendreher, schwarze Spitze

Ball Tip Screwdrivers, black tips

Tournevis à tête sphérique, extrémité noire

Destornilladores con punta esférica, punta negra

Bestell-Nr. Part No. Référence No. Referencia No.		Klingenlänge Blade Lame Hoja	Heftgröße Handle Manche Mango	Gewicht Weight Poids Peso
		mm	mm	g
00 7052 0300	3	100	90 x 25	30
00 7052 0400	4	100	90 x 25	38
00 7052 0500	5	100	100 x 28	56
00 7052 0600	6	125	110 x 31	94
00 7052 0800	8	150	125 x 36	158

## 7078



### Schraubendreher für Innentorxschrauben, schwarze Spitze

Screwdrivers for inside torx screws, black tips

Tournevis pour vis torx à empreinte femelle, extrémité noire

Destornilladores para tornillos torx interiores, punta negra

Bestell-Nr. Part No. Référence No. Referencia No.		Klingenlänge Blade Lame Hoja	Heftgröße Handle Manche Mango	Gewicht Weight Poids Peso
		mm	mm	g
00 7078 0006	TX 6	50	90 x 25	27
00 7078 0007	TX 7	50	90 x 25	27
00 7078 0008	TX 8	60	90 x 25	29
00 7078 0009	TX 9	60	90 x 25	29
00 7078 0010	TX 10	80	100 x 28	41
00 7078 0015	TX 15	80	100 x 28	42
00 7078 0020	TX 20	100	100 x 28	47
00 7078 0025	TX 25	100	110 x 31	61
00 7078 0027	TX 27	115	110 x 31	70
00 7078 0030	TX 30	115	110 x 31	76
00 7078 0040	TX 40	115	125 x 36	115
00 7078 0045	TX 45	130	125 x 36	136

**Schraubendreher für Innentorxschrauben mit Zentrierbohrung, schwarze Spitzen**

Screwdrivers for inside torx screws with hollow point, black tips

Tournevis pour vis torx à empreinte femelle, avec trou, extrémité noire

Destornilladores para tornillos torx interiores, antiforzaduras con agujero, punta negra

Bestell-Nr. Part No. Référence No. Referencia No.		Klingenlänge Blade Lame Hoja	Heftgröße Handle Manche Mango	Gewicht Weight Poids Peso
		mm	mm	g
00 7079 0010	TX 10	80	90 x 25	41
00 7079 0015	TX 15	80	90 x 25	42
00 7079 0020	TX 20	100	90 x 25	47
00 7079 0025	TX 25	100	100 x 31	61
00 7079 0027	TX 27	115	100 x 28	70
00 7079 0030	TX 30	115	100 x 28	76
00 7079 0040	TX 40	115	110 x 31	115
00 7079 0045	TX 45	130	125 x 36	136

7079



**Elektriker-Schraubendreher nach DIN EN 60900, AC 1000 und DC 1500 Volt, Schraubendreher nach DIN 7437**

Screwdrivers for electricians as per DIN EN 60900, 1000 volt AC or 1500 volt DC, screwdrivers for slotted screws, as per DIN 7437

Tournevis électrique selon DIN EN 60900, AC 1000 et DC 1500 Volt, tournevis pour vis à fente, selon DIN 7437

Destornilladores para electricistas según DIN EN 60900, 1000 Volt. AC o 1500 Volt. DC, punta plana, según DIN 7437

Bestell-Nr. Part No. Référence No. Referencia No.	 a x b	Klingenlänge Blade Lame Hoja	Heftgröße Handle Manche Mango	Gewicht Weight Poids Peso
	mm	mm	mm	g
00 7031 0100	0,4 x 2,5	75	90 x 25	28
00 7031 0200	0,8 x 4	100	90 x 25	39
00 7031 0300	1,0 x 5,5	125	100 x 28	70
00 7031 0400	1,2 x 6,5	150	110 x 31	95

7031



**Elektriker-Schraubendreher für Phillips-Schrauben, nach DIN EN 60900, AC 1000 und DC 1500 Volt, Schraubendreher nach DIN 5260/5261/ISO 8764**

Screwdrivers for Phillips-screws as per DIN EN 60900, 1000 volt AC or 1500 volt DC, screwdrivers as per DIN 5260/5261/ISO 8764

Tournevis électrique pour vis cruciforme Phillips, selon DIN EN 60900, AC 1000 et DC 1500 Volt, tournevis selon DIN 5260/5261/ISO 8764

Destornilladores para electricistas, para tornillos Phillips, según DIN EN 60900, 1000 Volt. AC o 1500 Volt. DC, destornilladores según DIN 5260/5261/ISO 8764

Bestell-Nr. Part No. Référence No. Referencia No.		Klingenlänge Blade Lame Hoja	Heftgröße Handle Manche Mango	Gewicht Weight Poids Peso
		mm	mm	g
00 7032 0100	PH 1	80	100 x 28	51
00 7032 0200	PH 2	100	110 x 31	76

7032



## SCHRAUBENDREHER

SCREWDRIVERS

TOURNEVIS

DESTORNILLADORES

### 7100/6K



#### Schraubendrehersatz, 6-tlg. in Kartonverpackung

Set, 6 screwdrivers in carton

Jeu de 6 tournevis,  
en boîte carton

Juego de 6 destornilladores en caja  
de carton

Bestell-Nr. Part No. Référence No. Referencia No.	Inhalt Contents Composition Contendio	Gewicht Weight Poids Peso
00 7100 0600	<ul style="list-style-type: none"> <li>⊕ PH 1 x 80 - PH 2 x 100</li> <li>● 4,5 x 75 - 5,5 x 100</li> <li>6,5 x 125 - 8,0 x 150</li> </ul>	g 424

### 7200/6K



#### Schraubendrehersatz für Torx-Schrauben, 6-tlg. in Kartonverpackung

Screwdriver set for torx-screws,  
with 6 screwdrivers in carton

Jeu de 6 tournevis pour vis torx, en  
boîte carton

Juego de 6 destornilladores para  
tornillos torx, en caja de carton

Bestell-Nr. Part No. Référence No. Referencia No.	Inhalt Contents Composition Contendio	Gewicht Weight Poids Peso
00 7200 0600	<ul style="list-style-type: none"> <li>⊕ TX 15, TX 20, TX 25, TX 27, TX 30, TX 40</li> </ul>	g 304

### 7300/6K



#### Schraubendrehersatz für Elektriker, 6-tlg. in Kartonverpackung

Screwdriver set for electricians,  
with 6 screwdrivers in carton

Jeu de 6 tournevis électrique,  
en boîte carton

Juego de 6 destornilladores para  
electricistas, en caja de carton

Bestell-Nr. Part No. Référence No. Referencia No.	Inhalt Contents Composition Contendio	Gewicht Weight Poids Peso
00 7300 0600	<ul style="list-style-type: none"> <li>⊕ PH 1 x 80 - PH 2 x 100</li> <li>● 2,5 x 75 - 4,0 x 100</li> <li>5,5 x 125 - 6,5 x 150</li> </ul>	g 371

**Spannungsprüfer mit Clip, Klinge vernickelt, isoliert, nach VDE 0680, 220 – 250 Volt**

Détecteur de tension avec clip, avec manche plastique, selon VDE 0680, 220 – 250 Volt

Voltmeter, with plastic handle and clip, as per VDE 0680, 220 – 250 Volt

Destornillador detector con sujetador segun VDE 0680, 220 – 250 Volt

Bestell-Nr. Part No. Référence No. Referencia No.	Klingenlänge Blade Lame Hoja	Länge Length Longueur Largo	Gewicht Weight Poids Peso
	mm	mm	g
00 7068 0000	65	145	14

7068



**Schraubendreher mit Sechskant, durchgehender Klinge, DIN 5264/5265 Lederklappenheft**

Tournevis à 6 pans, DIN 5264/5265, lame traversante, matechon cruiz

Screwdrivers with hexagon drive, wooden handle, DIN 5264/5265, leather tops

Destornilladore para taller, con hexágono, DIN 5264/5265, mango de madera

Bestell-Nr. Part No. Référence No. Referencia No.	 a x b	Klingenlänge Blade Lame Hoja	Heftgröße Handle Manche Mango	Gewicht Weight Poids Peso
	mm	mm	mm	g
00 7075 0100	1,0 x 5,5	100	100	70
00 7075 0200	1,2 x 7	125	110	110
00 7075 0300	1,2 x 9	150	120	180
00 7075 0400	1,6 x 10	175	125	230
00 7075 0500	2,0 x 12	200	125	280

7075



**Handhalter mit starkem Dauermagnet, Umschaltknarre und Magazinheft für 6 Bits**

Porte-embout tournevis, avec aimant permanent, cliquet réversible, et porte pour 6 embouts

Bits-handholder, with strong permanent magnet, reversible ratchet and hollow handle for 6 Bits

Mango con deposito, con imán permanente y chicharra intercambiable, deposito para 6 puntas

Bestell-Nr. Part No. Référence No. Referencia No.	Bits No.	Zoll Inch Pouce Pulgada	DIN	Länge Length Longueur Largo	Gewicht Weight Poids Peso
				mm	g
00 7325 0100	09 1875 0125 09 1875 0225 09 1875 0325 09 4595 0625 09 5595 0825 09 6095 1025	1/4"	D 6,3	175	210

7325 K





**STECKSCHLÜSSELEINSÄTZE, BETÄTIGT  
SOCKETS, RATCHETS AND ACCESSORIES  
DOUILLES, ACCESSOIRES  
BOCAS, ACCESORIOS**

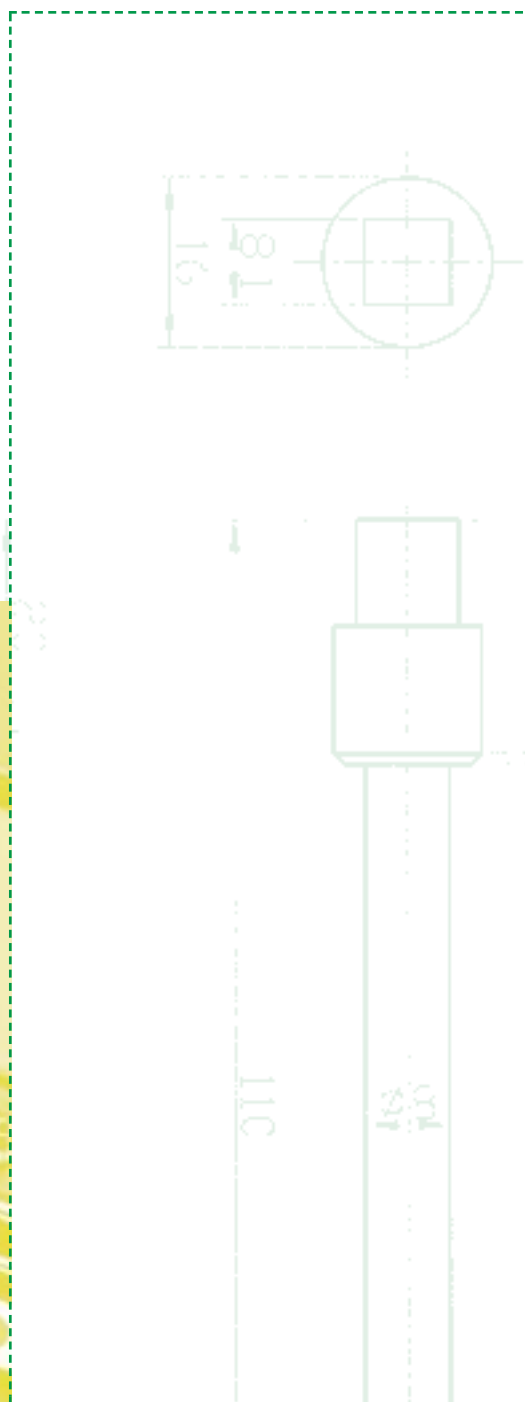
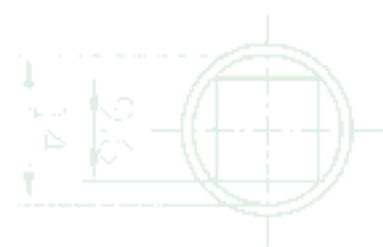

## D PRODUKTBESCHREIBUNG

**STECKSCHLÜSSELEINSÄTZE, BETÄTIGUNGSWERKZEUGE, STECKSCHLÜSSEL-GARNITUREN UND SORTIMENTE HANDSTECKSCHLÜSSELEINSÄTZE NACH DIN 3124/ISO 2725 SCHRAUBEN-DREHEREINSÄTZE NACH DIN 7422 SOWIE WEITERE STECKSCHLÜSSEL – ALLE FÜR DIE HANDBETÄTIGUNG BESTIMMT**

Übrige Ausführung nach den technischen Lieferbedingungen DIN 899. Die SALTUS-Steckschlüssel werden aus Chrom-Vanadium-Stahl nach den neuesten Erkenntnissen der Verformungstechnik gefertigt. Sie zeichnen sich durch hohe Drehmomente und enorme Verschleißfestigkeit aus. Präzision ist dabei oberstes SALTUS-Prinzip: Schlüsselweiten und Antriebsvierkante sind eng toleriert. Laufende Qualitätskontrollen gewährleisten höchsten Produktstandard. Die Flat-Drive-Schlüsselöffnung trägt zur Entlastung der auftretenden Kräfte an den Greifzonen bei. Standzeiten werden wesentlich erhöht, die Kanten von Schrauben und Muttern bleiben unbelastet. Eine sichere Verbindung und Handhabung wird durch ein Kugelfangloch, eine Kugelfangrinne oder durch eine Stiftsicherung gewährleistet. Steckschlüsselgarnituren und Sortimente stehen jeweils in optimaler Bestückung für den professionellen Anwender, die moderne Kfz-Werkstatt oder den anspruchsvollen Heimwerker zur Verfügung.

## GB PRODUCT DESCRIPTION

US SOCKETS, RATCHETS, SOCKET-ASSORTMENTS

HAND SOCKETS TO DIN 3124/ISO 2725 SCREWDRIVER INSERTS (BITS) TO DIN 7422 AND OTHER SPANNERS, ALL FOR HAND USE. ALL OTHER PARTS ACCORDING TO THE TECHNICAL REGULATIONS OF DIN 899.

SALTUS sockets are manufactured from Chrome-Vanadium-Steel according to the latest forming know-how, achieving high torque and extreme wear resistance. At SALTUS, precision is the prime directive, with close tolerances for widths and square drives. Permanent quality controls ensure highest product standards.

The flat-drive wrench helps relieve slip at the grip-zone. Prolongation of service life is thus achieved, plus edges of screws and nuts remain undamaged. Secure connection and handling is ensured by a ball-hole or pin holder.

Sets and assortments are available in many varieties for the professional user, automobile work-shops and for the high demands of all users.



notions de la technique de forge. Elles se profilent par des couples de serrage très forts et une énorme résistance à l'usure. La précision est chez SALTUS le principe primordial: Ouverture des clefs et entraînement quatre pans ont des tolérances étroites.

Des contrôles continus de qualité garantissent le standard le plus élevé du produit.

L'ouverture „FLAT-DRIVE“ des clefs contribue à une réduction de force d'appui dans les zones de grip.

On obtient une plus grande longévité, les arêtes ne subissent pas d'usure.

A l'aide d'un dispositif de verrouillage, chanfrein ou goupille de sécurité on obtient une jonction facile entre douilles et accessoires.

Jeux et assortiments sont équipés au mieux pour l'utilisateur traditionnel pour l'atelier d'entretien voiture et pour le bricoleur exigeant.

## E DESCRIPCIÓN DE LOS PRODUCTOS

LLAVES PARA APRETAR TUERCAS, GATILLOS

Llaves para apretar tuercas, gatillos, surtidos de llaves.

Llaves de apriete, gatillos en DIN 3124/ISO 2725.

Piezas de suplemento para destornilladores (filos) en DIN 7422 y otras llaves de tubo, todo para uso manual.

Todas las otras partes están fabricadas según las regulaciones técnicas, en DIN 899.

Las llaves de paso SALTUS, están fabricadas en acero-cromo-vanadio, siguiendo los últimos conocimientos técnicos, obteniendo un alto momento de fuerza y una gran resistencia.

En SALTUS, la precisión es la directiva de la perfección, con tolerancias exactas de arrastre. Los controles de calidad aseguran los más altos productos de la gama.

Las llaves fijas de impacto evitan que resbale la zona de amarre. Con ello se consigue mayor vida de la herramienta y la arista de los tornillos y tuercas no se daña.

La conexión o amarre se garantiza mediante bola o pin posicionador.

Los surtidos de llaves están disponibles en muchas variedades para el uso profesional de los automóviles, talleres de coches, y para las altas demandas de los usuarios.

## F DESCRIPTIF TECHNIQUE CONSELS D'UTILISATION

DOUILLES ET ACCESSOIRES

Douilles et accessoires, assortiments et jeux de clefs à douille.

Clefs à douille d'après DIN 3124/ISO 2725

Tournevis d'après DIN 7422 ainsi que d'autres types de douilles prévus pour la manutention.

L'énumération précédente d'après les conditions de livraison techniques DIN 899.

Les douilles SALTUS sont usinées en acier chrome-vanadium, d'après les dernières

# NGSWERKZEUGE

# STECKSCHLÜSSELEINSÄTZE, BETÄTIGUNGSWERKZEUGE

SOCKETS, RATCHETS AND ACCESSORIES

DOUILLES, ACCESSOIRES

BOCAS, ACCESORIOS

## 1/4" 5000 - 5001



### Steckschlüsseinsätze und Doppelsechskant, DIN 3124/ISO 2725-1, mit 1/4" Vierkantantrieb

Sockets, hexagon and bihexagon, with 1/4" square drive, DIN 3124/ISO 2725-1

Douilles à 6 pans et à 12 pans, carré 1/4", DIN 3124/ISO 2725-1

Bocas, arrastre 1/4", hexágono, y doble hexágono, DIN 3124, /ISO 2725-1

Bestell-Nr. Part No. Référence No. Referencia No.	mm	mm	Länge Length Longueur Largo	Gewicht Weight Poids Peso
00 5000 0035	3,5	3,5	25	10
00 5000 0004	4	4	25	10
00 5000 0045	4,5	4,5	25	10
00 5000 0005	5	5	25	10
00 5000 0055	5,5	5,5	25	10
00 5000 0006	6	6	25	10
00 5000 0007	7	7	25	12
00 5000 0008	8	8	25	12
00 5000 0009	9	9	25	13
00 5000 0010	10	10	25	16
00 5000 0011	11	11	25	18
00 5000 0012	12	12	25	19
00 5000 0013	13	13	25	22
00 5000 0014	14	14	25	26

## 1/4" 5002



### Steckschlüsseinsätze, Sechskant und Doppelsechskant lange Ausführung, DIN 3124/ISO 2725-1, mit 1/4" Vierkantantrieb

Sockets long pattern, with 1/4" square drive, hexagon and bihexagon, DIN 3124/ISO 2725-1

Douilles à 6 pans et à 12 pans, carré, 1/4", DIN 3124/ISO 2725-1

Bocas largas, arrastre 1/4", hexágono, y doble hexágono, DIN 3124/ISO 2725-1

Bestell-Nr. Part No. Référence No. Referencia No.	mm	mm	Länge Length Longueur Largo	Gewicht Weight Poids Peso
00 5002 0603	3	3	50	17
00 5002 0604	4	4	50	17
00 5002 0605	5	5	50	20
00 5002 0606	6	6	50	24
00 5002 0607	7	7	50	25
00 5002 0608	8	8	50	29
00 5002 0609	9	9	50	30
00 5002 0610	10	10	50	34
00 5002 0611	11	11	50	43
00 5002 0612	12	12	50	50
00 5002 0613	13	13	50	50
00 5002 0614	14	14	50	50

## 1/4" 5010



### Schraubendrehereinsätze für Innensechskantschrauben, DIN 7422

Sockets for hollow hex head screws, DIN 7422

Douilles tournevis à 6 pans mâles, DIN 7422

Bocas para tornillos de hexágonos interiores, DIN 7422

Bestell-Nr. Part No. Référence No. Referencia No.	mm	Länge Length Longueur Largo	Gewicht Weight Poids Peso
00 5010 0003	3	32	13
00 5010 0004	4	32	14
00 5010 0005	5	32	14
00 5010 0006	6	32	15
00 5010 0008	8	32	17

**Schraubendrehereinsätze für Kreuzschlitzschrauben, DIN 5260**

Douilles tournevis pour vis cruciformes, DIN 5260

Sockets for Phillips-Recess screws, DIN 5260

Bocas de destornilladores para tornillos de Phillips, DIN 5260

Bestell-Nr. Part No. Référence No. Referencia No.		Länge Length Longueur Largo	Gewicht Weight Poids Peso
		mm	g
00 5015 0100	PH 1	32	9
00 5015 0200	PH 2	32	10
00 5015 0300	PH 3	32	11

1/4" 5015



**Schraubendrehereinsätze für Schlitzschrauben, DIN 5264**

Douilles tournevis pour vis à fente, DIN 5264

Sockets for slotted screws, DIN 5264

Bocas de destornilladores para tornillos de cabeza ranurada, DIN 5264

Bestell-Nr. Part No. Référence No. Referencia No.		Länge Length Longueur Largo	Gewicht Weight Poids Peso
		mm	g
00 5020 0100	0,8 x 5,5	32	13
00 5020 0200	1,0 x 5,5	32	13
00 5020 0300	1,2 x 6,5	32	14
00 5020 0400	1,2 x 8,0	32	15
00 5020 0500	1,5 x 10,0	32	17

1/4" 5020



**Schraubendrehereinsätze für Innentorxschrauben**

Douilles tournevis pour vis torx empreinte femelle

Sockets for inside torx screws

Bocas de destornilladores, para tornillos torx interiores

Bestell-Nr. Part No. Référence No. Referencia No.		Länge Length Longueur Largo	Gewicht Weight Poids Peso
		mm	g
00 5025 0010	TX 10	28	10
00 5025 0015	TX 15	28	10
00 5025 0020	TX 20	28	11
00 5025 0025	TX 25	28	11
00 5025 0027	TX 27	28	12
00 5025 0030	TX 30	28	12
00 5025 0040	TX 40	28	13

1/4" 5025



# STECKSCHLÜSSELEINSÄTZE, BETÄTIGUNGSWERKZEUGE

SOCKETS, RATCHETS AND ACCESSORIES

DOUILLES, ACCESSOIRES

BOCAS, ACCESORIOS

## 1/4" 5038



### Steckschlüsseinsätze mit Gelenk, Sechskant, 1/4" Vierkantantrieb

Sockets with hinge joint, hexagon, with 1/4" square drive

Douilles à 6 pans, avec cardan, carre 1/4"

Bocas con articulación, hexágono arrastre 1/4"

Bestell-Nr. Part No. Référence No. Referencia No.		Länge Length Longueur Largo	Gewicht Weight Poids Peso
		mm	g
00 5038 0008	8	34	20
00 5038 0009	9	34	20
00 5038 0010	10	36	23
00 5038 0011	11	37	24
00 5038 0012	12	37	26
00 5038 0013	13	38	28

## 1/4" 5078



### Steckschlüsseinsätze für Außentorxschrauben, mit 1/4" Vierkantantrieb

Sockets for outside torx screws, with 1/4" square drive

Douilles pour vis torx à empreinte mâle, carre 1/4"

Bocas, arrastre 1/4", para tornillos torx exteriores

Bestell-Nr. Part No. Référence No. Referencia No.		Länge Length Longueur Largo	Gewicht Weight Poids Peso
		mm	g
00 5078 0004	E 4	22	7
00 5078 0005	E 5	22	8
00 5078 0006	E 6	22	8
00 5078 0007	E 7	22	9
00 5078 0008	E 8	22	9
00 5078 0010	E 10	22	10

## 1/4" 5087-5088



### Hebelumschaltratsche, DIN 3122

Reversible Ratchet, DIN 3122

Cliquet réversible, DIN 3122

Chicharra reversible, DIN 3122

Bestell-Nr. Part No. Référence No. Referencia No.	Länge Length Longueur Largo	Gewicht Weight Poids Peso
	mm	g
00 5087 0000	145	130



### Hebelumschaltratsche für Bits DIN 3126 – C 6,3

Reversible Ratchet for bits DIN 3126 – C 6,3

Cliquet réversible, pour embouts à 6 pans intérieur DIN 3126 – C 6,3

Chicharra reversible hexágono interior DIN 3126 – C 6,3

Bestell-Nr. Part No. Référence No. Referencia No.	Länge Length Longueur Largo	Gewicht Weight Poids Peso
	mm	g
00 5088 0000	145	124

**Antriebs- und Verbindungsteile 1/4", nach DIN 3122 – 3123/ISO 3315 – 3316, verchromt**

Handles and parts as per  
DIN 3122 – 3123/ISO 3315 – 3316  
chrome plated

Accessoires  
DIN 3122 – 3123/ISO 3315 – 3316,  
chromés

Accesorios  
DIN 3122 – 3123/ISO 3315 – 3316,  
cromados

Bestell-Nr. Part No. Référence No. Referencia No.	Bezeichnung Description Désignation Descripción	Länge Length Longueur Largo	Gewicht Weight Poids Peso
		mm	g
00 5027 0000	<b>Aufsteckratsche</b> Ratchet Cliquet Chicharra	35	55
00 5032 0000	<b>Gelenk-Bit-Halter 1/4" x 1/4"</b> Bit-Holder U-Joint 1/4" x 1/4" Porte-embouts cardan 1/4" x 1/4" Acoplamiento rótula, para puntas 1/4" x 1/4"	39	28
00 5035 0000	<b>Kardangelenk</b> Universal joint Cardan Rótula universal	35	23
00 5040 0000	<b>Verlängerung 2"</b> Extension 2" Rallonge 2" Extensión medio 2"	50	25
00 5041 0000	<b>Verlängerung 3"</b> Extension 3" Rallonge 3" Extensión largo 3"	75	35
00 5041 0100	<b>Verlängerung 4"</b> Extension 4" Rallonge 4" Extensión largo 4"	100	46
00 5042 0000	<b>Verlängerung 6"</b> Extension 6" Rallonge 6" Extensión 6"	150	70
00 5045 0000	<b>Gelenkgriff</b> Flexible handle Poignée articulée Mango à carden	145	73
00 5055 0000	<b>T-Gleitgriff</b> Sliding T-handle Poignée coulissante Barra corredeiza	105	40
00 5060 0000	<b>Vergrößerungsstück 1/4" innen, 3/8" außen</b> Adaptor 1/4" female, 3/8" male Agumentateur 1/4" – 3/8" Enchufe 1/4" int. 3/8" ext.	25	20
00 5063 0000	<b>Bit-Halter 1/4" x 1/4"</b> Bit-holder 1/4" x 1/4" Porte-embouts 1/4" x 1/4" Acoplamiento para puntas 1/4" x 1/4"	25	15
00 5065 0000	<b>Reduzierstück 3/8" innen, 1/4" außen</b> Adaptor 3/8" female, 1/4" male Réducteur 1/4" – 3/8" Enchufe 3/8" int. 1/4" ext.	75	40
00 5070 0000	<b>Plastik-Festgriff</b> Holder with plastic handle Poignée plastique Mango prolongador	145	90
00 5075 0000	<b>Knarre, umsteckbar</b> Ratchet Cliquet interchangeable Chicharra	150	90
00 5076 0000	<b>Ersatzvierkant</b> Coupler Carré de rechange Cuadrado de remplazo	24	16



## STECKSCHLÜSSELEINSÄTZE, BETÄTIGUNGSWERKZEUGE

SOCKETS, RATCHETS AND ACCESSORIES

DOUILLES, ACCESSOIRES

BOCAS, ACCESORIOS

### 3/8" 5105 - 5106



**Steckschlüsseinsätze, Sechskant und Doppelsechskant, DIN 3124/ISO 2725, mit 3/8" Vierkantantrieb, Bohrung (DIN 3120 D) – Kugelrille (DIN 3120 C)**

Douilles, à 6 pans et à 12 pans, carré, 3/8", DIN 3124/ISO 2725

Bocas, arrastre 3/8", hexágono, y doble hexágono, DIN 3124/ISO 2725

Sockets, with 3/8" square drive, hexagon and bihexagon, DIN 3124/ISO 2725

Bestell-Nr. Part No. Référence No. Referencia No.	⊘ mm	Bestell-Nr. Part No. Référence No. Referencia No.	⊘ mm	Länge Length Longueur Largo	Gewicht Weight Poids Peso
00 5105 0006	6	00 5106 0006	6	26	22
00 5105 0007	7	00 5106 0007	7	26	22
00 5105 0008	8	00 5106 0008	8	26	22
00 5105 0009	9	00 5106 0009	9	26	22
00 5105 0010	10	00 5106 0010	10	26	22
00 5105 0011	11	00 5106 0011	11	26	24
00 5105 0012	12	00 5106 0012	12	26	25
00 5105 0013	13	00 5106 0013	13	26	30
00 5105 0014	14	00 5106 0014	14	26	31
00 5105 0015	15	00 5106 0015	15	26	35
00 5105 0016	16	00 5106 0016	16	26	42
00 5105 0017	17	00 5106 0017	17	26	50
00 5105 0018	18	00 5106 0018	18	26	50
00 5105 0019	19	00 5106 0019	19	29	50
00 5105 0020	20	00 5106 0020	20	29	60
00 5105 0021	21	00 5106 0621	21	29	60
00 5105 0022	22	00 5106 0622	22	29	70

### 3/8" 5107



**Steckschlüsseinsätze, Sechskant und Doppelsechskant, lange Ausführung, DIN 3124/ISO 2725, mit 3/8" Vierkantantrieb, Bohrung (DIN 3120 D) – Kugelrille (DIN 3120 C)**

Douilles longues, à 6 pans et à 12 pans, carré, 3/8", DIN 3124/ISO 2725

Bocas largas, arrastre 3/8", hexágono, y doble hexágono, DIN 3124/ISO 2725

Sockets long pattern, with 3/8" square drive, hexagon and bihexagon, DIN 3124/ISO 2725

Bestell-Nr. Part No. Référence No. Referencia No.	⊘ mm	Bestell-Nr. Part No. Référence No. Referencia No.	⊘ mm	Länge Length Longueur Largo	Gewicht Weight Poids Peso
00 5107 0010	10	00 5107 0610	10	63,5	49
00 5107 0011	11	00 5107 0611	11	63,5	52
00 5107 0012	12	00 5107 0612	12	63,5	55
00 5107 0013	13	00 5107 0613	13	63,5	72
00 5107 0014	14	00 5107 0614	14	63,5	73
00 5107 0015	15	00 5107 0615	15	63,5	81
00 5107 0016	16	00 5107 0616	16	63,5	98
00 5107 0017	17	00 5107 0617	17	63,5	103
00 5107 0018	18	00 5107 0618	18	63,5	109
00 5107 0019	19	00 5107 0619	19	63,5	124
00 5107 0020	20	00 5107 0620	20	63,5	135
00 5107 0021	21	00 5107 0621	21	63,5	152
00 5107 0022	22	00 5107 0622	22	63,5	184

**Schraubendrehereinsätze für Innensechskantschrauben, mit 3/8" Vierkantantrieb, Bohrung (DIN 3120 D) – Kugelrille (DIN 3120 C)**

Douilles tournevis à 6 pans mâles, carré 3/8"

Bocas de destornilladores, para tornillos de hexágonos interiores, arrastre 3/8"

Sockets for hollow hex head screws, with 3/8" square drive

Bestell-Nr. Part No. Référence No. Referencia No.		Länge Length Longueur Largo	Gewicht Weight Poids Peso
		mm	g
00 5121 0003	3	50	36
00 5121 0004	4	50	37
00 5121 0005	5	50	38
00 5121 0006	6	50	38
00 5121 0007	7	50	38
00 5121 0008	8	50	40
00 5121 0010	10	50	42

3/8" 5121



**Schraubendrehereinsätze für Innentorxschrauben, mit 3/8" Vierkantantrieb, Bohrung (DIN 3120 D) – Kugelrille (DIN 3120 C)**

Douilles tournevis pour vis torx empreinte femelle, carré 3/8"

Bocas de destornilladores, para tornillos torx interiores, arrastre 3/8"

Sockets for inside torx screws, with 3/8" square drive

Bestell-Nr. Part No. Référence No. Referencia No.		Länge Length Longueur Largo	Gewicht Weight Poids Peso
		mm	g
00 5125 0009	TX 9	49,5	36
00 5125 0010	TX 10	49,5	36
00 5125 0015	TX 15	49,5	36
00 5125 0020	TX 20	49,5	36
00 5125 0025	TX 25	49,5	36
00 5125 0027	TX 27	49,5	37
00 5125 0030	TX 30	49,5	37
00 5125 0040	TX 40	49,5	40
00 5125 0045	TX 45	49,5	45
00 5125 0050	TX 50	49,5	50
00 5125 0055	TX 55	49,5	55

3/8" 5125



**Steckschlüsseleinsätze mit Gelenk für Außentorxschrauben, DIN 3124**

Douilles cardan, pour vis torx à empreinte male, DIN 3124

Sockets with hinge joint, for outside torx screws, DIN 3124

Bocas con articulación, para tornillos torx exteriores, DIN 3124

Bestell-Nr. Part No. Référence No. Referencia No.		Länge Length Longueur Largo	Gewicht Weight Poids Peso
		mm	g
00 5137 0008	E 8	46	60
00 5137 0010	E 10	48	60
00 5137 0012	E 12	48	60
00 5137 0014	E 14	50	62

3/8" 5137



## STECKSCHLÜSSELEINSÄTZE, BETÄTIGUNGSWERKZEUGE

SOCKETS, RATCHETS AND ACCESSORIES

DOUILLES, ACCESSOIRES

BOCAS, ACCESORIOS

### 3/8" 5138



#### Steckschlüsseinsätze mit Gelenk, Sechskant, mit 3/8" Vierkanttrieb, Bohrung (DIN 3120 D) – Kuglrille (DIN 3120 C)

Sockets with hinge joint, hexagon, with 3/8" square drive

Douilles à 6 pans, avec cardan, carre 3/8"

Bocas con articulación, hexágono arrastre 3/8"

Bestell-Nr. Part No. Référence No. Referencia No.		Länge Length Longueur Largo	Gewicht Weight Poids Peso
		mm	g
00 5138 0010	10	48	58
00 5138 0011	11	50	60
00 5138 0012	12	50	62
00 5138 0013	13	51	62
00 5138 0014	14	51	64
00 5138 0015	15	53	68
00 5138 0016	16	53	72
00 5138 0017	17	55	74
00 5138 0018	18	55	78
00 5138 0019	19	55	84

### 3/8" 5178



#### Steckschlüsseinsätze für Außentorxschrauben, mit 3/8" Vierkanttrieb, DIN 3124, Bohrung (DIN 3120 D) – Kuglrille (DIN 3120 C)

Sockets for outside torx screws, with 3/8" square drive

Douilles pour vis torx à empreinte mâle, carre 3/8"

Bocas, arrastre 3/8", para tornillos torx exteriores

Bestell-Nr. Part No. Référence No. Referencia No.		Länge Length Longueur Largo	Gewicht Weight Poids Peso
		mm	g
00 5178 0004	E 4	26	18
00 5178 0005	E 5	26	20
00 5178 0006	E 6	26	21
00 5178 0007	E 7	26	22
00 5178 0008	E 8	26	23
00 5178 0010	E 10	26	24
00 5178 0011	E 11	26	25
00 5178 0012	E 12	26	26
00 5178 0014	E 14	26	27
00 5178 0016	E 16	26	27

**Antriebs- und Verbindungsteile  
3/8", nach DIN 3122 – 3123/  
ISO 3315 – 3316, verchromt**

Handles and parts as per  
DIN 3122 – 3123/ISO 3122 – 3123,  
chrome plated

Accessoires DIN 3122 – 3123/  
ISO 3122 – 3123, chromés

Accesorios DIN 3122 – 3123/  
ISO 3122 – 3123, cromados

Bestell-Nr. Part No. Référence No. Referencia No.	Bezeichnung Description Désignation Descripción	Länge Length Longueur Largo	Gewicht Weight Poids Peso
		mm	g
00 5123 0000	<b>Zündkerzeneinsatz SW 20,8 – 12 kt</b> Socket for spark plugs Douille à bougie Bocas para bujías	70	165
00 5123 0620	<b>Zündkerzeneinsatz SW 20,8 – 6 kt</b> Socket for spark plugs Douille à bougie Bocas para bujías	70	165
00 5127 0000	<b>Aufsteckknarre</b> Ratchet Cliquet Chicharra adaptable reversible	52	190
00 5130 0000	<b>Schraubendrehereinsatz</b> Socket for slotted screws Douille tournevis Boca de destornilladores	50	45
00 5132 0000	<b>Gelenk-Bit-Halter 3/8" x 5/16"</b> Bit-Holder U-Joint 3/8" x 5/16" Porte-embouts cardan 3/8" x 5/16" Acoplamiento rótula, para puntas 3/8" x 5/16"	49	64
00 5135 0000	<b>Kardangelenk</b> Universal joint Cardan Rótula universal	50	60
00 5139 0000	<b>Verlängerung 3"</b> Extension 3" Rallonge 3" Extensión 3"	75	68
00 5140 0000	<b>Verlängerung 5"</b> Extension 5" Rallonge 5" Extensión 5"	125	110
00 5141 0000	<b>Verlängerung 10"</b> Extension 10" Rallonge 10" Extensión 10"	250	220
00 5155 0000	<b>T-Gleitgriff</b> Sliding T-handle Poignée coulissante Barra corrediza	250	150
00 5160 0000	<b>Vergrößerungsstück 3/8" innen, 1/2" außen</b> Adaptor 3/8" female male 1/2" Augmentateur 3/8" – 1/2" Enchufe 3/8" int. 1/2" ext.	36	46
00 5163 0000	<b>Bit Halter 3/8" x 1/4"</b> Bit holder 3/8" x 1/4" Porte-Embouts 3/8" x 1/4" Acoplamiento para puntas 3/8" x 1/4"	30	32
00 5165 0000	<b>Reduzierstück 1/2" innen, 3/8" außen</b> Adaptor 1/2" female, 3/8" male Réducteur 1/2" – 3/8" Enchufe 1/2" int. 3/8" ext.	135	44
00 5175 0000	<b>Knarre umsteckbar</b> Ratchet w. coupler Cliquet interchangeable Chicharra	195	202
00 5176 0000	<b>Ersatzvierkant</b> Coupler Carré de rechange Cuadrado de remplazo	24	15
00 5180 0000	<b>Bit Halter 3/8" x 5/16"</b> Bit holder 3/8" x 5/16" Porte-Embouts 3/8" x 5/16" Acoplamiento para puntas 3/8" x 5/16"	38	55
00 5187 0000	<b>Hebelumschaltknarre</b> Reversible ratchet Cliquet, reversible Chicharra reversible	185	300

**3/8" 5123 - 5187**



## STECKSCHLÜSSELEINSÄTZE, BETÄTIGUNGSWERKZEUGE

SOCKETS, RATCHETS AND ACCESSORIES

DOUILLES, ACCESSOIRES

BOCAS, ACCESORIOS

### 1/2" 5200



**Steckschlüsseinsätze mit 1/2" Vierkantantrieb nach DIN 3124, Einsätze werden mit einseitiger Bohrung (DIN 3120 D) und Kugelrille (DIN 3120 C) geliefert**

Douilles à 12 pans, carré 1/2", DIN 3124/3120 D/3120 C

Bocas, doble hexágono, arrastre 1/2", DIN 3124/3120 D/3120 C

Sockets with 1/2" square drive, bihexagon, as per DIN 3124/3120 D/3120 C

Bestell-Nr. Part No. Référence No. Referencia No.		Länge Length Longueur Largo	Gewicht Weight Poids Peso
	mm	mm	g
00 5200 0008	8	38	45
00 5200 0009	9	38	45
00 5200 0010	10	38	48
00 5200 0011	11	38	50
00 5200 0012	12	38	50
00 5200 0013	13	38	50
00 5200 0014	14	38	50
00 5200 0015	15	38	55
00 5200 0016	16	38	65
00 5200 0017	17	38	70
00 5200 0018	18	38	70
00 5200 0019	19	38	70
00 5200 0020	20	38	70
00 5200 0021	21	38	80
00 5200 0022	22	40	100
00 5200 0023	23	40	100
00 5200 0024	24	43	100
00 5200 0025	25	43	122
00 5200 0026	26	43	132
00 5200 0027	27	43	154
00 5200 0030	30	43	174
00 5200 0032	32	43	190

### 1/2" 5201



**Steckschlüsseinsätze mit 1/2" Vierkant-Antrieb nach DIN 3124, Einsätze werden mit einseitiger Bohrung (DIN 3120 D) und Kugelrille (DIN 3120 C) geliefert**

Douilles à 6 pans, carré 1/2", DIN 3124/3120 D/3120 C

Bocas, hexágono, arrastre 1/2", DIN 3124/3120 D/3120 C

Sockets with 1/2" square drive, hexagon, as per DIN 3124/3120 D/3120 C



Bestell-Nr. Part No. Référence No. Referencia No.		Länge Length Longueur Largo	Gewicht Weight Poids Peso
	mm	mm	g
00 5201 0008	8	38	45
00 5201 0009	9	38	45
00 5201 0010	10	38	48
00 5201 0011	11	38	50
00 5201 0012	12	38	50
00 5201 0013	13	38	50
00 5201 0014	14	38	50
00 5201 0015	15	38	55
00 5201 0016	16	38	65
00 5201 0017	17	38	70
00 5201 0018	18	38	70
00 5201 0019	19	38	70
00 5201 0020	20	38	70
00 5201 0021	21	38	80
00 5201 0022	22	40	100
00 5201 0023	23	40	100
00 5201 0025	25	43	122
00 5201 0026	26	43	132
00 5201 0024	24	40	100
00 5201 0027	27	43	154
00 5201 0030	30	43	174
00 5201 0032	32	43	190
00 5201 0036	36	47	340

**Steckschlüsseleinsätze, Sechskant und Doppelsechskant, lange Ausführung, DIN 3124, mit 1/2" Vierkantantrieb, Bohrung (DIN 3120 D) – Kugelrille (DIN 3120 C)**

Douilles longues, à 6 pans et à 12 pans, carré, 1/2", DIN 3124

Bocas largas, arrastre 1/2", hexágono y doble hexágono, DIN 3124

Sockets long pattern, with 1/2" square drive, hexagon and bihexagon, DIN 3124

Bestell-Nr. Part No. Référence No. Referencia No.		Bestell-Nr. Part No. Référence No. Referencia No.		Länge Length Longueur Largo	Gewicht Weight Poids Peso
	mm		mm	mm	g
00 5202 0010	10	00 5202 0610	10	80	104
00 5202 0011	11	00 5202 0611	11	80	105
00 5202 0012	12	00 5202 0612	12	80	111
00 5202 0013	13	00 5202 0613	13	80	115
00 5202 0014	14	00 5202 0614	14	80	118
00 5202 0015	15	00 5202 0615	15	80	123
00 5202 0016	16	00 5202 0616	16	80	123
00 5202 0017	17	00 5202 0617	17	80	145
00 5202 0018	18	00 5202 0618	18	80	158
00 5202 0019	19	00 5202 0619	19	80	175
00 5202 0020	20	00 5202 0620	20	80	183
00 5202 0021	21	00 5202 0621	21	80	183
00 5202 0022	22	00 5202 0622	22	80	212
00 5202 0024	24	00 5202 0624	24	80	207
00 5202 0027	27	00 5202 0627	27	80	345
00 5202 0030	30	00 5202 0630	30	80	336
00 5202 0032	32	00 5202 0632	32	80	336

1/2" 5202



**Steckschlüsseleinsätze für Außentorxschrauben, mit 1/2" Vierkantantrieb, DIN 3124, Bohrung (DIN 3120 D) – Kugelrille (DIN 3120 C)**

Douilles pour vis torx à empreinte mâle, carre 1/2"

Bocas, arrastre 1/2", para tornillos torx exteriores

Sockets for outside torx screws, with 1/2" square drive

Bestell-Nr. Part No. Référence No. Referencia No.		Länge Length Longueur Largo	Gewicht Weight Poids Peso
		mm	g
00 5278 0010	E 10	36	44
00 5278 0011	E 11	37	45
00 5278 0012	E 12	37	47
00 5278 0014	E 14	37	48
00 5278 0016	E 16	37	57
00 5278 0018	E 18	37	57
00 5278 0020	E 20	37	63
00 5278 0024	E 24	40	92

1/2" 5278



# STECKSCHLÜSSELEINSÄTZE, BETÄTIGUNGSWERKZEUGE

SOCKETS, RATCHETS AND ACCESSORIES

DOUILLES, ACCESSOIRES

BOCAS, ACCESORIOS

## 1/2" 5219



Sonderlängen auf Anfrage  
Special lengths on request  
Longueur speciale sur demande  
Largos diferentes a petición

### Schraubendrehereinsätze für Innentorxschrauben

Sockets for inside torx screws

Douilles tournevis pour vis torx empreinte femelle

Bocas de destornilladores, para tornillos torx interiores

Bestell-Nr. Part No. Référence No. Referencia No.		Länge Length Longueur Largo	Gewicht Weight Poids Peso
		mm	g
00 5219 0005	M 5	52	73
00 5219 0006	M 6	52	64
00 5219 0008	M 8	53	74
00 5219 0010	M 10	53	83
00 5219 0012	M 12	55	112
00 5219 0014	M 14	58	118
00 5219 0108	M 8	100	94
00 5219 0110	M 10	100	115
00 5219 0120	M 12	100	156

## 1/2" 5220



### Schraubendrehereinsätze für Ribe-Schrauben

Sockets for Ribe screws

Douilles tournevis pour vis Ribe

Bocas de destornilladores, para tornillos Ribe

Bestell-Nr. Part No. Référence No. Referencia No.		Länge Length Longueur Largo	Gewicht Weight Poids Peso
		mm	g
00 5220 0005	M 5	63	76
00 5220 0006	M 6	63	66
00 5220 0008	M 8	63	76
00 5220 0010	M 10	63	89
00 5220 0012	M 12	63	118
00 5220 0014	M 14	63	124

## 1/2" 5237



### Steckschlüsseleinsätze mit Gelenk für Außentorxschrauben, DIN 3124

Sockets with hinge joint, for outside torx screws, DIN 3124

Douilles cardan, pour vis torx à empreinte male, DIN 3124

Bocas con articulación, para tornillos torx exteriores, DIN 3124

Bestell-Nr. Part No. Référence No. Referencia No.		Länge Length Longueur Largo	Gewicht Weight Poids Peso
		mm	g
00 5237 0010	E 10	62	135
00 5237 0012	E 12	65	138
00 5237 0014	E 14	65	138

**Schraubendrehereinsätze  
für Innensechskantschrauben,  
mit 1/2" Vierkantantrieb,  
Bohrung (DIN 3120 D) –  
Kugelrille (DIN 3120 C)**

Sockets for hollow hex head  
screws, with 1/2" square drive

Douilles tournevis à 6 pans mâles,  
carré 1/2"

Bocas de destornilladores, para  
tornillos de hexágonos interiores,  
arrastre 1/2"

Bestell-Nr. Part No. Référence No. Referencia No.		Länge Length Longueur Largo	Gewicht Weight Poids Peso
		mm	g
00 5221 0005	5	57	62
00 5221 0006	6	57	64
00 5221 0007	7	57	64
00 5221 0008	8	57	74
00 5221 0010	10	57	83
00 5221 0012	12	57	94
00 5221 0014	14	57	105
00 5221 0017	17	57	143
00 5221 0019	19	60	182
00 5221 0108	8	80	85
00 5221 0110	10	140	142

1/2" 5221



Sonderlängen auf Anfrage  
Special lengths on request  
Longueur speciale sur demande  
Largos diferentes a petición

**Schraubendrehereinsätze  
für Innentorxschrauben,  
mit 1/2" Vierkantantrieb,  
Bohrung (DIN 3120 D) –  
Kugelrille (DIN 3120 C)**

Sockets for inside torx screws,  
with 1/2" square drive

Douilles tournevis pour vis torx  
empreinte femelle, carré 1/2"

Bocas de destornilladores,  
para tornillos torx interiores,  
arrastre 1/2"

Bestell-Nr. Part No. Référence No. Referencia No.		Länge Length Longueur Largo	Gewicht Weight Poids Peso
		mm	g
00 5225 0020	TX 20	55	64
00 5225 0025	TX 25	55	64
00 5225 0027	TX 27	55	64
00 5225 0030	TX 30	55	64
00 5225 0040	TX 40	55	64
00 5225 0045	TX 45	55	74
00 5225 0050	TX 50	55	74
00 5225 0055	TX 55	56	80
00 5225 0060	TX 60	56	80

1/2" 5225



Sonderlängen auf Anfrage, mit Zentrierbohrung auf Anfrage  
Special lengths on request, with hollow point on request  
Longueur speciale sur demande, avec trou sur demande  
Largos diferentes a petición, con agujero a petición

# STECKSCHLÜSSELEINSÄTZE, BETÄTIGUNGSWERKZEUGE

SOCKETS, RATCHETS AND ACCESSORIES

DOUILLES, ACCESSOIRES

BOCAS, ACCESORIOS

## 1/2" 5203 - 5287



### Antriebs- und Verbindungsteile nach DIN 3122 - 3123/ ISO 3315 - 3316, verchromt

Handles and parts per DIN 3122/3123/ISO 3315 - 3316, chrome plated

Accessoires DIN 3122/3123/ ISO 3315 - 3316, chromé

Accesorios DIN 3122/3123/ ISO 3315 - 3316, cromados

Bestell-Nr. Part No. Référence No. Referencia No.	Bezeichnung Description Désignation Descripción	Länge Length Longueur Largo	Gewicht Weight Poids Peso
		mm	g
00 5203 0000	<b>Kardangelenk</b> Universal joint Cardan Rótula universal	70	150
00 5204 0000	<b>Verlängerung 10"</b> Extension 10" Rallonge 10" Extensión 10"	250	340
00 5205 0000	<b>T-Gleitgriff</b> Sliding T-handle Poignée coulissante Barra corrediza	300	450
00 5206 0000	<b>Kurbel</b> Speed brace Vilbrequin Manivela	420	595
00 5208 0000	<b>Verlängerung 5"</b> Extension 5" Rallonge 5" Extensión 5"	125	185
00 5208 0075	<b>Verlängerung 3"</b> Extension 3" Rallonge 3" Extensión 3"	75	110
00 5209 0000	<b>Schraubendreher</b> Screwdriver Douilles tournevis Destornillador	53	77
00 5210 0000	<b>Ersatzvierkant</b> Coupler Carré de rechange Cuadrado de remplazo	36	42
00 5211 0000	<b>Vergrößerungsstück 1/2" - 3/4"</b> Adaptor 1/2" - 3/4" Augmentateur 1/2" - 3/4" Enchufe 1/2" int. 3/4" ext.	42	107
00 5214 0000	<b>Gelenkgriff</b> Flex handle Poignée articulée Mango articulado	265	401
00 5217 0000	<b>Umsteckknarre</b> Ratchet Cliquet réversible Chicharra	250	450
00 5223 0020	<b>Zündkerzeneinsatz 20,8 mm/13/16" - 12 kt</b> Deep socket for spark plugs Douilles à bougie, extra profondes Boca para bujias super hondo	70	165
00 5223 0620	<b>Zündkerzeneinsatz 20,8 mm/13/16" - 6 kt</b> Deep socket for spark plugs Douilles à bougie, extra profondes Boca para bujias super hondo	70	165
00 5227 0000	<b>Aufsteckknarre</b> Ratchet Cliquet Chicharra	56	208
00 5280 0000	<b>Bit-Halter 1/2" x 5/16"</b> Bit holder 1/2" x 5/16" Porte-Embouts 1/2" x 5/16" Acoplamiento para puntas 1/2" x 5/16"	38	55
00 5287 0000	<b>Hebelumschaltknarre</b> Reversible ratchet with lever Cliquet réversible à levier Chicharra réversible	260	600

**Steckschlüsseleinsätze,  
Sechskant, DIN 3124/  
ISO 2725 – 1, mit 3/4" Vierkant-  
antrieb**

Sockets, with 3/4" square drive,  
hexagon, DIN 3124/ISO 2725 –1

Douilles à 6 pans, carré 3/4",  
DIN 3124/ISO 2725 –1

Bocas hexágono, arrastre 3/4",  
DIN 3124/ISO 2725 –1

3/4" 5305



Bestell-Nr. Part No. Référence No. Referencia No.		Länge Length Longueur Largo	Gewicht Weight Poids Peso
	mm	mm	g
00 5305 0019	19	50	215
00 5305 0022	22	50	225
00 5305 0024	24	50	235
00 5305 0026	26	52	235
00 5305 0027	27	52	240
00 5305 0030	30	52	270
00 5305 0032	32	54	300
00 5305 0033	33	56	330
00 5305 0035	35	58	400
00 5305 0036	36	58	430
00 5305 0038	38	60	500
00 5305 0041	41	64	600
00 5305 0044	44	66	660
00 5305 0046	46	68	700
00 5305 0050	50	72	850
00 5305 0055	55	77	960
00 5305 0060	60	78	1100

**Umsteckknarre**

Ratchet

Cliquet réversible

Chicharra reversible

Bestell-Nr. Part No. Référence No. Referencia No.	Länge Length Longueur Largo	Gewicht Weight Poids Peso
	mm	g
00 5375 0000	490	1600
00 5377 0000	340	1200

3/4" 5375 - 5377



**Hebelumschaltknarre**

Ratchet, reversible

Cliquet réversible

Chicharra reversible

Bestell-Nr. Part No. Référence No. Referencia No.	Länge Length Longueur Largo	Gewicht Weight Poids Peso
	mm	g
00 5387 0000	500	2000

3/4" 5387



# STECKSCHLÜSSELEINSÄTZE, BETÄTIGUNGSWERKZEUGE

SOCKETS, RATCHETS AND ACCESSORIES

DOUILLES, ACCESSOIRES

BOCAS, ACCESORIOS

## 3/4" 5327 - 5376



### Antriebs- und Verbindungsteile nach DIN 3122 – 3123/ ISO 3315 – 3316, verchromt

Handles and parts per DIN 3122 – 3123/ISO 3315 – 3316, chrome plated

Accessoires DIN 3122 – 3123/ ISO 3315 – 3316, chromé

Accesorios DIN 3122 – 3123/ ISO 3315 – 3316, cromados

Bestell-Nr. Part No. Référence No. Referencia No.	Bezeichnung Description Désignation Descripción	Länge Length Longueur Largo	Gewicht Weight Poids Peso
		mm	g
00 5327 0000	<b>Aufsteckknarre</b> Ratchet Cliquet Chicharra	95	1000
00 5335 0000	<b>Kardangelenk</b> Universal joint Cardan Rotula universal	110	605
00 5339 0000	<b>Verlängerung 4"</b> Extension 4" Rallonge 4" Extensión 4"	100	411
00 5340 0000	<b>Verlängerung 8"</b> Extension 8" Rallonge 8" Extensión 8"	200	650
00 5341 0000	<b>Verlängerung 16"</b> Extension 16" Rallonge 16" Extensión 16"	400	1180
00 5355 0000	<b>T-Gleitgriff</b> Sliding T-handle Poignée coulissante Barra corrediza	500	1400
00 5360 0000	<b>Vergrößerungsstück 3/4" innen, 1" außen</b> Adaptor 3/4" female, 1" male Augmentateur 3/4" – 1" Enchufe 3/4" int., 1" ext.	59	271
00 5365 0000	<b>Reduzierstück 3/4" innen, 1/2" außen</b> Adaptor 3/4" female 1/2" male Réducteur 3/4" – 1/2" Enchufe 3/4" int., 1/2" ext.	57	179
00 5376 0000	<b>Ersatzvierkant</b> Coupler Carré de rechange Cuadrado de remplazo	42	120

**Steckschlüsseinsätze,  
Doppelsechskant, DIN 3124/  
ISO 2725 – 1, mit 1" Vierkant-  
antrieb**

Sockets, bihexagon with 1" square  
drive, DIN 3124/ISO 2725 – 1

Douilles à 12 pans,  
carré 1", DIN 3124/ISO 2725 – 1

Bocas doble hexagono,  
arrastre 1", DIN 3124/ISO 2725 – 1

Bestell-Nr. Part No. Référence No. Referencia No.		Länge Length Longueur Largo	Gewicht Weight Poids Peso
	mm	mm	g
00 5400 0036	36	70	750
00 5400 0041	41	80	920
00 5400 0046	46	80	980
00 5400 0050	50	80	1100
00 5400 0055	55	80	1180
00 5400 0060	60	80	1500
00 5400 0065	65	80	1800
00 5400 0070	70	80	2000
00 5400 0075	75	86	2200
00 5400 0080	80	90	2500

1" 5400



**Antriebs- und Verbindungsteile 1"  
Vierkantantrieb, nach  
DIN 3122 – 3123/ ISO 3315 – 3316**

Handles and Parts with 1" square  
drive, as per DIN 3122 – 3123/  
ISO 3315 – 3316

Accessoires, carré 1",  
DIN 3122 – 3123/ISO 3315 – 3316

Accesorios, arrastre 1",  
DIN 3122 – 3123/ISO 3315 – 3316

Bestell-Nr. Part No. Référence No. Referencia No.	Bezeichnung Description Désignation Descripción	Länge Length Longueur Largo	Gewicht Weight Poids Peso
		mm	g
00 5440 0000	<b>Verlängerung 8"</b> Extension 8" Rallonge 8" Extensión 8"	200	1200
00 5441 0000	<b>Verlängerung 16"</b> Extension 16" Rallonge 16" Extensión 16"	400	2150
00 5455 0000	<b>T-Gleitgriff</b> Sliding T-handle Poignée coulissante Barra corrediza	630	2500
00 5460 0000	<b>Vergrößerungsstück 1" innen, 1 1/2" außen</b> Adaptor 1" female, 1 1/2" male Augmentateur 1" x 1 1/2" Enchufe 1" int., 1 1/2" ext.	70	720
00 5465 0000	<b>Reduzierstück 1" innen, 3/4" außen</b> Adaptor 1" female 3/4" male Réducteur 1" x 3/4" Enchufe 1" int., 3/4" ext.	80	500
00 5475 0000	<b>Knarre, umschaltbar</b> Reversible ratchet Cliquet réversible Chicharra, reversible	700	3750

1" 5440 - 5475



5440 – 5441



5455



5460

5465



5475

# STECKSCHLÜSSELEINSÄTZE, BETÄTIGUNGSWERKZEUGE

SOCKETS, RATCHETS AND ACCESSORIES

DOUILLES, ACCESSOIRES

BOCAS, ACCESORIOS

## 1/4" 5038



### Steckschlüsselsatz, im Metallkasten

Socket Set, in metal box

Jeu de douilles, en boîte metal

Juego de bocas, en cajita de metal

Bestell-Nr. Part No. Référence No. Referencia No.	Inhalt Contents Composition Contenido	Gewicht Weight Poids Peso
00 5038 0000	5038 – 8, 9, 10, 11, 12, 13	g 520

## 1/4" 5098 U-TX



### Steckschlüsselsatz für Innen- und Außentorx-Schrauben im Metallkasten

Socket Set for inside and outside torx screws, in metal box

Jeu de douilles pour vis torx à empreinte femelle et vis torx à empreinte male, en boîte metal

Juego de bocas para tornillos torx interiores y exteriores, en cajita de metal

Bestell-Nr. Part No. Référence No. Referencia No.	Inhalt Contents Composition Contenido	Gewicht Weight Poids Peso
00 5098 0000	5037, 5040, 5042, 5070, 5087 5078 E 4, E 5, E 6, E 7, E 8, E 10 5025 TX 10, TX 15, TX 20, TX 25, TX 27, TX 30, TX 40	g

## 1/4" 5099 U-MM



### Steckschlüsselsätze, im Metallkasten oder schlagfester Kunststoffbox

Socket sets, in metal box or plastic box

Jeux de douilles, en boîte metal ou plastique

Juegos de bocas, en cajita de metal o plástico

Bestell-Nr. Part No. Référence No. Referencia No.	Inhalt Contents Composition Contenido	Gewicht Weight Poids Peso
00 5099 0900	5087 5070 5035, 5035, 5055	g 920
00 5099 0800 (Metallkasten)	5041 5042 5000 – 4, 5, 6, 7, 8, 9, 10, 11, 12, 13, 14 mm 5010 – 3, 4, 5, 6, 8 mm 5015 – 1, 2, 3 mm 5020 – 1, 3, 5 mm	g 960

5099 U-MM, Metall



5099 U-MM

## Steckschlüsselsätze

Jeux de douilles

Socket Sets

Juegos de bocas

Bestell-Nr. Part No. Référence No. Referencia No.	Inhalt Contents Composition Contenido	Gewicht Weight Poids Peso
00 5190 0900	○ 5123/5130/5135/5140/5141/5155/5187 5105 – 6, 7, 8, 9, 10, 11, 12, 13, 14, 15, 16, 17, 18, 19, 20, 21, 22 mm	g 3520
00 5190 0960	○ 5106 – 6, 7, 8, 9, 10, 11, 12, 13, 14, 15, 16, 17, 18, 19, 20, 21, 22 mm	3520
00 5190 0800 (Metallkasten)	○ 5123/5130/5135/5140/5141/5155/5187 ○ 5106 – 6, 7, 8, 9 ○ 5105 – 10, 11, 12, 13, 14, 15, 16, 17, 18, 19, 20, 21, 22 mm	3650

## 3/8" 5190



5190 U-MM



5190 U- MM, Metall

## Steckschlüsselsatz, mit Gelenkeinsätzen

Jeux de douilles avec cardan

Socket Set,  
with sockets hinge joint

Juego de bocas con articulación

Bestell-Nr. Part No. Référence No. Referencia No.	Inhalt Contents Composition Contenido	Gewicht Weight Poids Peso
00 5138 0000	5138 – 10, 11, 12, 13, 14, 15, 17, 19	g 1045

## 3/8" 5138



## Steckschlüsselsätze

Jeux de douilles

Socket Sets

Juegos de bocas

Bestell-Nr. Part No. Référence No. Referencia No.	Inhalt Contents Composition Contenido	Gewicht Weight Poids Peso
00 5199 0900	○ 5035/5041/5042/5055/5070/5087 5000 – 4, 5, 6, 7, 8, 9, 10, 11, 12, 13, 14 mm 5010 – 3, 4, 5, 6, 8 mm 5015 – GR 1, 2, 3 5020 – 1, 3, 5 mm 5123/5130/5135/5140/5141/5155/5187 5105 – 6, 7, 8, 9, 10, 11, 12, 13, 14, 15, 16, 17, 18, 19, 20, 21, 22 mm	g 4440
00 5199 0960	○ 5035/5041/5042/5055/5070/5087 5000 – 4, 5, 6, 7, 8, 9, 10, 11, 12, 13, 14 mm 5010 – 3, 4, 5, 6, 8 mm 5015 – GR 1, 2, 3 5020 – 1, 3, 5 mm 5123/5130/5135/5140/5141/5155/5187 5106 – 6, 7, 8, 9, 10, 11, 12, 13, 14, 15, 16, 17, 18, 19, 20, 21, 22 mm	4440

## 1/4" + 3/8" 5199



5199 U-MM

# STECKSCHLÜSSELEINSÄTZE, BETÄTIGUNGSWERKZEUGE

SOCKETS, RATCHETS AND ACCESSORIES

DOUILLES, ACCESSOIRES

BOCAS, ACCESORIOS

## 1/2" 5245



5245 U-MM



5245 U-MM, Metall

### Steckschlüsselsätze

Socket sets

Jeux de douilles

Juegos de bocas

Bestell-Nr. Part No. Référence No. Referencia No.	Inhalt Contents Composition Contenido	Gewicht Weight Poids Peso
00 5245 0900	5203/5204/5205/5223/5208/5287 5200 – 10, 11, 12, 13, 14, 15, 16, 17, 18, 19, 20, 21, 22, 23, 24, 27, 30, 32 mm	g 5924
00 5245 0960	5203/5204/5205/5223/5208/5287 5201 – 10, 11, 12, 13, 14, 15, 16, 17, 18, 19, 20, 21, 22, 23, 24, 27, 30, 32 mm	5924
00 5245 0800 (Metallkasten)	5203/5204/5205/5223/5208/5287 5200 – 10, 11, 12, 13, 14, 15, 16, 17, 18, 19, 20, 21, 22, 23, 24, 27, 30, 32 mm	6000

## 1/4" + 1/2" 5299



### Steckschlüsselsatz für Innen- und Außentorx-Schrauben, im Metallkasten

Socket Set for inside and outside torx screws, in metal box

Jeu de douilles pour vis torx à empreinte femelle et vis torx à empreinte male, en boîte metal

Juegos de bocas para tornillos torx interiores y exteriores, en cajita de metal

Bestell-Nr. Part No. Référence No. Referencia No.	Inhalt Contents Composition Contenido	Gewicht Weight Poids Peso
00 5299 0000	1/4" – 5041/5042/5087 5025 – TX 10, TX 15, TX 20, TX 25, TX 27 5078 – E 4, E 5, E 6, E 7, E 8 1/2" – 5204/5208/5287 5225 – TX 30, TX 40, TX 45, TX 50, TX 55, TX 60 5278 – E 10, E 11, E 12, E 14, E 16, E 18, E 20, E 24	g 3800

## 3/4" 5345 - 5390



5390 U-MM, Metall



5345 U-MM

### Steckschlüsselsätze

Socket sets

Jeux de douilles

Juegos de bocas

Bestell-Nr. Part No. Référence No. Referencia No.	Inhalt Contents Composition Contenido	Gewicht Weight Poids Peso
00 5390 0000 (Metallkasten)	5340/5341/5355/5387 5305 – 22, 24, 27, 29, 30, 32, 36, 38, 41, 46, 50 mm	g 10500
00 5345 0900	5339/5340/5341/5355/5387 5305 – 22, 24, 26, 27, 30, 32, 33, 35, 36, 38, 41, 46, 50, 55 mm	10220

### Steckschlüsselsatz

Socket Set

Jeu de douilles

Juego de bocas

Bestell-Nr. Part No. Référence No. Referencia No.	Inhalt Contents Composition Contenido	Gewicht Weight Poids Peso
		g
00 5490 0000	5440 5441 5475 5400 – 36, 41, 46, 50, 55, 60, 65, 70	10500

1" 5490



### Steckschlüsselsatz, mit 1/4" und 5/16" Torx-Bits und Bit-Haltern, 32-tlg., für Innentorx-Schrauben

Socket Set, of 1/4" and 5/16" torx bits with bit holders, 32 parts, for inside torx screws

Jeu de douilles, avec embouts torx 1/4" et 5/16" et porte-embouts, 32 pièces, pour vis torx à empreinte femelle

Juego de bocas, con bits 1/4" + 5/16" y accoplamientos, 32 piezas, para tornillos torx interiores

Bestell-Nr. Part No. Référence No. Referencia No.	Inhalt Contents Composition Contenido	Gewicht Weight Poids Peso
		g
00 5578 0000	1/4" = L 26 mm 092078 TX – TX 6, TX 7, TX 8, TX 9, TX 10, TX 15, TX 20, TX 25, TX 27, TX 30 5/16" = L 35 mm 102078 TX – TX 40, TX 45, TX 50, TX 55 5063 – 1/4" x 1/4" 5163 – 3/8" x 1/4" 5180 – 3/8" x 5/16" 5280 – 1/2" x 5/16"	820

5578



### Steckschlüsselsatz, mit 1/4", 3/8" und 1/2" Vierkanttrieb, für Außentorx-Schrauben

Socket Set, with 1/4", 3/8" and 1/2" square drive, for outside torx screws

Jeu de douilles, carré 1/4", 3/8" et 1/2", pour vis torx à empreinte male

Juego de bocas, arrastre 1/4", 3/8" y 1/2", para tornillos torx exteriores

Bestell-Nr. Part No. Référence No. Referencia No.	Inhalt Contents Composition Contenido	Gewicht Weight Poids Peso
		g
00 5678 0000	5078 – E 4, E 5, E 6 5178 – E 8, E 10, E 12 5278 – E 14, E 18, E 20	680

5678



## STECKSCHLÜSSELEINSÄTZE, BETÄTIGUNGSWERKZEUGE

SOCKETS, RATCHETS AND ACCESSORIES

DOUILLES, ACCESSOIRES

BOCAS, ACCESORIOS

### 5778 - 5878



3/8", 5778



1/2", 5878

#### Steckschlüsselsätze, mit Gelenkeinsätzen für Außentorxschrauben, im Metallkasten

Socket Sets, with hinge joint sockets, for outside torx screws, in metal box

Jeux de douilles, avec cardan, pour vis torx à empreinte male, en boîte metal

Juegos de bocas, con articulación, para tornillos torx exteriores, en cajita de metal

Bestell-Nr. Part No. Référence No. Referencia No.	Inhalt Contents Composition Contenido	Gewicht Weight Poids Peso
00 5778 0000	5137 - E 8, E 10, E 12, E 14	620
00 5878 0000	5237 - E 10, E 12, E 14	698

### 5978



#### Steckschlüsselsatz, 58-tlg., für Innen- und Außentorx-Schrauben, im Metallkasten

Socket Set, 58 parts, for inside and outside torx screws, in metal box

Jeu de douilles, 58 pièces, pour vis torx à empreinte femelle et vis torx à empreinte male, en boîte metal

Juego de bocas, 58 piezas, para tornillos torx interiores y exteriores, en cajita de metal

Bestell-Nr. Part No. Référence No. Referencia No.	Inhalt Contents Composition Contenido	Gewicht Weight Poids Peso
00 5978 0000	278 - E 6 x E 8, E 10 x E 12, E 14 x E 18, E 20 x E 24	4610
	3060 - TX 6, TX 7, TX 8, TX 9, TX 10, TX 15, TX 20, TX 25, TX 27, TX 30, TX 40	
	5088 - 11978	
	5163 - 3/8" x 1/4"	
	5125 - TX 40, TX 45	
	7078 - TX 6, TX 7, TX 8, TX 9, TX 10, TX 15, TX 20, TX 25, TX 27, TX 30	
	5078 - E 4, E 5, E 6, E 7, E 8	
	5178 - E 10, E 11, E 12, E 14	
	5278 - E 16, E 18, E 20, E 24	
	5225 - TX 50, TX 55, TX 60	
	092078 - TX 626	
	092078 - TX 7, TX 8, TX 9, TX 10, TX 15, TX 20, TX 25, TX 27, TX 30, TX 40	
	092078 - TX 2526 = 65 mm	
	11978	

## Werkstattwagen SALTUS

Tool Trolley SALTUS

Servante d'atelier SALTUS

Carretilla de herramientas SALTUS

Bestell-Nr. Part No. Référence No. Referencia No.	Größe Size Dimension Tamaño	Gewicht Weight Poids Peso
	mm	g
00 4220 0001	870 x 520 x 750	48000

# 4220L



## Werkzeugkoffer, leer, 3- bzw. 5-tlg.

Tool Boxes, empty,  
3 or 5 trays

Coffrets à outils,  
3 au 5 compartiments

Cajas de herramientas,  
3 ó 5 secciones

Bestell-Nr. Part No. Référence No. Referencia No.	Größe Size Dimension Tamaño	Gewicht Weight Poids Peso
	mm	g
00 4310 0001	530 x 200 x 200 (5-tlg.)	6700
00 4340 0001	420 x 200 x 150 (3-tlg.)	4100

# 4310L - 4340L



# STECKSCHLÜSSELEINSÄTZE, BETÄTIGUNGSWERKZEUGE

SOCKETS, RATCHETS AND ACCESSORIES

DOUILLES, ACCESSOIRES

BOCAS, ACCESORIOS

## 0-4220/1 25



Werkzeug-Sortiment, 125-tlg.

Assortiment d'outils, 125 pièces

Tool-Assortment, 125 parts

Juego de herramientas, 125 piezas

Bestell-Nr. Part No. Référence No. Referencia No.	Bezeichnung Description Désignation Articulos	
00 4220 0125	Gabelschlüsselsatz / Open End spanner set / Jeu clés à fourches doubles / Juego llaves de dos bocas	50/8 MM
	Ringschlüsselsatz / Ring spanner set / Jeu clés polygonales / Juego llaves de dos bocasen estrellada bocas en estrella	450/8 MM
	Gabel-Ringschlüsselsatz / Combination spanner set / Jeu clés mixtes / Juego llaves combinadas	1000/16S MM
	Steckschlüsselsatz 1/4" / Socket set / Jeu de douilles 1/4" / Juego de bocas 1/4"	5099 U-MM
	Steckschlüsselsatz 3/8" / Socket set / Jeu de douilles 3/8" / Juego de bocas 3/8"	5190 U-MM
	Satz Einsätze 1/2" 6kt. / Set 1/2" dr. sockets 6 pt. / Douilles 1/2" / Juego de bocas 1/2"	5201
	Reduzierstück 3/8" innen, 1/2" außen/ Adaptor 3/8" jeu female, 1/2" male / Augmentateur 3/8" – 1/2" / Enchufe 3/8" – 1/2"	5160
	Umschaltknarre 1/2" / Reversible ratchet 1/2" / Cliquet reversible 1/2" / Chicharra reversible 1/2"	5287
	Verlängerung 5" / Extension 5" / Rallonge 5" / Extensión 5"	5208
	Rollgabelschlüssel 8" / Crescent wrench 8" / Clés à molette 8" / Llave inglesa 8"	570-43-8"
	Sechskantschraubendreher / Screwdriver with hexagon drive / Tournevis d'atelier avec bague 6 pans / Destornillador mecánico con hexágono	7000/1
	Sechskantschraubendreher / Screwdriver with hexagon drive / Tournevis d'atelier avec bague 6 pans / Destornillador mecánico con hexágono	7000/2
	Sechskantschraubendreher / Screwdriver with hexagon drive / Tournevis d'atelier avec bague 6 pans / Destornillador mecánico con hexágono	7000/3
	Werkstatt-Schraubendreher / Engineer's Screwdriver / Tournevis d'atelier / Destornillador para taller	7016/2
	Elektriker-Schraubendreher / Electrician's Screwdriver / Tournevis électricien / Destornillador electricista	7026/1
	Kreuzschlitz-Schraubendreher / Screwdriver for Phillips screws / Tournevis pour vis cruciforme Phillips / Destornillador tipo Phillips	7040/1
	Kreuzschlitz-Schraubendreher / Screwdriver for Phillips screws / Tournevis pour vis cruciforme Phillips / Destornillador tipo Phillips	7040/2
	Stiftschlüsselsatz / Allen wrenches set / Jeu clés mâles / Juego llaves hexagonales	3050
	Seitenschneider / Diagonal cutter / Pincers coupantes de côté / Alicates de corte lateral	204-45-180
	Wasserpumpenzange / Double groove joint plier / Pincers multiprises / Pinzas para bombas de agua	506-55-240
	Kombizange / Combination plier / Pincers universelles / Alicates universales	105-45-180
	Flachrundzange / Long chain nose plier / Pincers demi-roundes / Alicates de bocas semi-redondas	170-45-200
	Seegerzange I2 / Circlip plier I2 / Pincers pour circlips I2 / Alicates para anillos I2	4103-10-175
	Seegerzange A2 / Circlip plier A2 / Pincers pour circlips A2 / Alicates para anillos A2	4003-10-175
	Werkzeugsatz Meißel und Körner / Set of chisel and punches / Jeu burins-bedanes / Juego de cinceles y punzones	8260
	Hohlschaber / Three square hollow ground scraper / Grattoir triangulaire / Rascadores forma triangulo	8320/3
	Schlosserhammer / Engineer's hammer / Marteau de serrurier / Martillo para mecánicos	6610/3
	Plastikhammer / Plastic hammer / Maillets plastique / Martillo plastico	6421/3
	Fühlerlehre / Feeler gauges / Jauges d'épaisseur / Galgas	11540/3
	Ölspritzkanne / Oiler / Burette à huile à pompe / Aceitera	11800
	Lilliputsäge / Handsaw / Petite scie / Sierra de mano	8401

# 0-4220/61



**Werkzeug-Sortiment, 61-tlg.**

Assortiment d'outils, 61 pièces

Tool-Assortment, 61 parts

Juego de herramientas, 61 piezas

Bestell-Nr. Part No. Référence No. Referencia No.	Bezeichnung Description Désignation Articulos	
00 4220 0061	Satz Gabel-Ringschlüsselsatz 15-tlg. / Combination spanner set / Jeu clés mixtes / Juego llaves combinadas	1000/15-tlg.
	Satz lose Einsätze 1/2" 12kt. /Set 1/2" dr. sockets 12 pt. / Douilles 1/2" / Bocas 1/2"	5200/5-tlg.
	Verlängerung 10" / Extension 10" / Rallonge 10" / Extension 10"	5204
	Verlängerung 5" / Extension 5" / Rallonge 5" / Extension 5"	5208
	Umschalratsche 1/2" / Reversible Ratchet 1/2" / Cliquet reversible 1/2" / Chicharra reversible 1/2"	5287
	Elektriker-Schraubendreher / Electrician's Screwdriver / Tournevis d'électricien / Destornillador para electricistas	7031/1
	Elektriker-Schraubendreher / Electrician's Screwdriver / Tournevis d'électricien / Destornillador para electricistas	7031/2
	Pozidriv-Schraubendreher / Screwdriver for Pozidriv screws / Tournevis pour vis Pozidriv / Destornillador tipo Pozidriv	7050/2
	Pozidriv-Schraubendreher / Screwdriver for Pozidriv screws / Tournevis pour vis Pozidriv / Destornillador tipo Pozidriv	7050/3
	Dreikant-Hohlschaber / Three Square hollow ground scraper / Grattoir triangulaire / Rascador forma triangulo	8320/1
	Flachmeißel / Flat chisel / Burins / Cincel plano	8100/6
	Kreuzmeißel / Cape chisel / Bedanes / Cincel agudo	8120/5
	Durchtreiber / Drift punches / Chasse pointes / Punzon	8150/4
	Durchtreiber / Drift punches / Chasse pointes / Punzon	8150/8
	Körner / Center punches / Pointeau / Centro punzones	8200
	Splintentreiber / Drift pins / Chasse goupilles / Punzones para passadores	8250/2
	Kombizange / Combination plier / Pincas universelles de mécanicien / Alicates universal	105-45-180
	Seitenschneider / Diagonal cutter / Pincas coupantes de côté / Alicates de corte lateral	204-45-180
	Wasserpumpenzange / Double groove joint plier / Pincas multiprises / Pinza para bombas de agua	506-55-240
	Schlosserhammer / Engineer's hammer / Matreau de serrurier / Martillo para mecánicos	6610/3
	Drahtbürste / Wire brush / Brosse à manche / Cepillo de alambre	11900
	Fühlerlehren / Feeler gauges / Jauges d'épaisseur / Galgas	11540/3
	Autolichtprüfer / Car light tester / Controleur d'éclairage / Destornillador comprobador	11780
	Plastik-Hammer / Plastic hammer / Maillets plastique / Martillo de plastico	6421/3
	Satz Stiftschlüssel / Allen wrenches set / Jeu clés mâles / Juego llaves hexagonales	3050
	Combi-Crimp-Zange / Universal-Crimping plier / Pince à sertir / Alicates para presnar y entallar	711-11-235

Weitere Sortimente auf Anfrage  
Further Assortments on request  
Autres Assortiments sur demande  
Otros Juegos a petición

**KFZ- UND SPEZIAL-WERKZEUGE**

AUTOMOTIVE AND SPECIAL TOOLS

OUTILS SPÉCIAUX POUR AUTOMO

HERRAMIENTAS ESPECIALES



# BIILES PARA EL AUTOMOVIL

## D PRODUKTBESCHREIBUNG

### KFZ-SPEZIALWERKZEUG, REPARATUR- UND MONTAGEWERKZEUG, HÄMMER, ABZIEHER

Unsere Kfz-Spezialwerkzeuge wurden in enger Zusammenarbeit mit führenden Automobilherstellern entwickelt, um in der Werkzeugentwicklung mit dem technischen Fortschritt, den jedes neue Modell mit sich bringt, Schritt zu halten.

Darüber hinaus bietet SALTUS eine vielfältige Auswahl an Werkzeugen, die in verschiedenen Bereichen eingesetzt werden können. Mit genauen Kontrollen stellt das SALTUS-Qualitätsmanagement auch hier sicher, dass die vorgeschriebene Qualität erreicht wird und alle Normen erfüllt sind.

## GB PRODUCT DESCRIPTION

## US AUTOMOTIVE AND SPECIAL TOOLS

Our automotive tools have been developed in co-operation with leading automobile manufacturers to keep up with the technical progress made with every new car model.

In addition, SALTUS offers a large variety of tools for different uses. The SALTUS quality management uses strict controls to make sure the specified quality is reached and all standards are met.

## F DESCRIPTIF TECHNIQUE CONSELS D'UTILISATION

### OUTILS SPÉCIAUX POUR AUTOMOBILES

Marteaux, extracteurs, outils spéciaux pour automobiles, outils de réparation et de montage.

Nos outils spéciaux pour automobiles ont été réalisés en collaboration étroite avec des constructeurs d'automobiles pour suivre le développement et le progrès technique amenés par chaque nouveau modèle.

En plus SALTUS présente un choix multiple d'outils qui peuvent être utilisés dans des domaines variés.

Avec des contrôles pénibles, le management de la qualité SALTUS assure que les données techniques et les normes sont respectées.

## E DESCRIPCIÓN DE LOS PRODUCTOS

### HERRAMIENTAS ESPECIALES PARA EL AUTOMOVIL.

Martillos, extractores, herramientas especiales para talleres, herramientas para reparación y ensamblaje.

Nuestras herramientas para coches, han estado desarrolladas en cooperación con los fabricantes de automóviles. Se desarrollan conjuntamente con los nuevos modelos con el fin de mantener el mismo progreso técnico.

Adicionalmente, SALTUS ofrece una extensa variedad de herramientas para diferentes usos. Los encargados de la calidad de SALTUS trabajan con unos estrictos controles, con el fin de asegurar el estándar de calidad para todos los modelos.

6411



Frühere Artikel-Nr. SALTUS 6650  
Former Part No. SALTUS 6650  
Référence No. ancien SALTUS 6650  
Referencia No. anterior SALTUS 6650

**Gummi-Kompositionshämmer  
nach DIN 5128-90,  
mit Eschenstiel**

Rubber mallets as per DIN 5128-90,  
with ash handle

Maillets caoutchouc selon  
DIN 5128-90, manche frêne

Martillos de goma según  
DIN 5128-90, con mango de  
fresno

Bestell-Nr. Part No. Référence No. Referencia No.	Größe Size Dimens. Tamaño	Gewicht Weight Poids Peso
ca. 90 Shore A	mm	g
6411 10000	40 x 80	150
6411 10010	54 x 90	305
6411 10020	64 x 113	490
6411 10030	74 x 127	740
6411 10040	90 x 139	1090

**Gummi-Elastikhämmer  
nach DIN 5128-60,  
mit Eschenstiel**

Rubber mallets as per DIN 5128-60,  
with ash handle

Maillets caoutchouc selon  
DIN 5128-60, manche frêne

Martillos de goma según  
DIN 5128-60, con mango de  
fresno

Bestell-Nr. Part No. Référence No. Referencia No.	Größe Size Dimension Tamaño	Gewicht Weight Poids Peso
ca. 60 Shore A	mm	g
6411 20000	40 x 80	150
6411 20010	54 x 90	305
6411 20020	64 x 113	490
6411 20030	74 x 127	740
6411 20040	90 x 139	1090

**Ersatzstiele, Esche**

Spare Handles, ash

Manches de rechange, frêne

Mangos de recambio, fresno

Bestell-Nr. Part No. Référence No. Referencia No.	Länge Length Longueur Largo	Gewicht Weight Poids Peso
	mm	g
6411 50000	260	40
6411 50010	320	80
6411 50020	340	100
6411 50030	360	150
6411 50040	380	150

**Plastikhämmer,  
mit Eschenstiel**

Plastic Hammers with ash handle

Maillets plastiques, avec manche  
frêne

Martillos de plástico, con mango  
de fresno

Bestell-Nr. Part No. Référence No. Referencia No.	Ø	Länge Length Longueur Largo	Gewicht Weight Poids Peso
	mm	mm	g
6421 11221	22 x 73	250	145
6421 11272	27 x 88	265	225
6421 11323	32 x 96	280	320
6421 11354	35 x 103	295	400
6421 11405	40 x 105	320	550
6421 11506	50 x 115	340	900
6421 11607	60 x 150	380	1360

**Plastikköpfe, lose, Paar**

Plastic Heads, loose, pairs

Embouts de rechange

Bocas de recambio

Bestell-Nr. Part No. Référence No. Referencia No.	Ø	Gewicht Weight Poids Peso
	mm	g
6421 21221	22 x 73	15
6421 21272	27 x 88	30
6421 21323	32 x 96	50
6421 21354	35 x 103	70
6421 21405	40 x 105	100
6421 21506	50 x 115	150
6421 21607	60 x 150	180

**Nylonhämmer**

Nylon Hammers

Maillets Nylon

Martillos de Nylon

Bestell-Nr. Part No. Référence No. Referencia No.	Ø	Länge Length Longueur Largo	Gewicht Weight Poids Peso
	mm	mm	g
6421 12221	22 x 73	250	145
6421 12272	27 x 88	265	225
6421 12323	32 x 96	280	320
6421 12354	35 x 103	295	400
6421 12405	40 x 105	320	550
6421 12506	50 x 115	340	900
6421 12607	60 x 150	380	1360

**Nyloneinsätze, lose, Paar**

Nylon Heads, loose, pairs

Embouts de rechange

Bocas de recambio

Bestell-Nr. Part No. Référence No. Referencia No.	Ø	Gewicht Weight Poids Peso
	mm	g
6421 22221	22 x 73	15
6421 22272	27 x 88	30
6421 22323	32 x 96	50
6421 22354	35 x 103	70
6421 22405	40 x 105	100
6421 22506	50 x 115	150
6421 22607	60 x 150	180

**6421 CA**



Frühere Artikel-Nr. SALTUS 6655/6656  
Former Part No. SALTUS 6655/6656  
Référence No. ancien SALTUS 6655/6656  
Referencia No. anterior SALTUS 6655/6656

**6421 N**



Frühere Artikel-Nr. SALTUS 6660/6661  
Former Part No. SALTUS 6660/6661  
Référence No. ancien SALTUS 6660/6661  
Referencia No. anterior SALTUS 6660/6661

## 6610



### Schlosserhämmer, DIN 1041, mit poliertem Eschenstiel

Machinists' Hammers, DIN 1041 with polished ash handles

Marteaux de serrurier, DIN 1041, manche frêne poli

Martillos para mecánicos, DIN 1041, con mango de fresno pulido

Bestell-Nr. Part No. Référence No. Referencia No.	Gewicht Weight Poids Peso
	g
00 6610 0100	100
00 6610 0200	200
00 6610 0300	300
00 6610 0400	400
00 6610 0500	500
00 6610 0800	800
00 6610 1000	1000
00 6610 1500	1500
00 6610 2000	2000

## 8100 - 8120



### Flachmeißel/Kreuzmeißel DIN 6453 /DIN 6451

Flat chisels/Cape chisels, DIN 6453/DIN 6451

Burins/Bédanes  
DIN 6453/DIN 6451

Cinceles planos/Cinceles agudos  
DIN 6453/DIN 6451

Bestell-Nr. Part No. Référence No. Referencia No.	Bestell-Nr. Part No. Référence No. Referencia No.	Länge Length Longueur Largo	Gewicht Weight Poids Peso
		mm	g
00 8100 0400	00 8120 0400	100	85
00 8100 0500	00 8120 0500	125	150
00 8100 0600	00 8120 0600	150	180
00 8100 0700	00 8120 0700	175	280
00 8100 0800	00 8120 0800	200	400

## 8150 - 8250



### Durchtreiber/Splintreiber, achtkantig, DIN 6458/DIN 6450

Drift punches/Drift pins, DIN 6458/DIN 6450

Chasse pointes/Chasse goupilles, octogones, DIN 6458/DIN 6450

Botadores/Punzones para grupillas, DIN 6458/DIN 6450

Bestell-Nr. Part No. Référence No. Referencia No.	Bestell-Nr. Part No. Référence No. Referencia No.	Ø	Länge Length Longueur Largo	Gewicht Weight Poids Peso
		mm	mm	g
00 8150 0200	00 8250 0200	2	120/150	90/60
00 8150 0300	00 8250 0300	3	120/150	90/60
00 8150 0400	00 8250 0400	4	120/150	90/70
00 8150 0500	00 8250 0500	5	120/150	90/70
00 8150 0600	00 8250 0600	6	150/150	140/70
00 8150 0800	00 8250 0800	8	175/150	195/100

### Schlitzmeißel

Jointing chisel

Burin, extra-plat

Cinceles para hendiduras

Bestell-Nr. Part No. Référence No. Referencia No.	Länge Length Longueur Largo	Gewicht Weight Poids Peso
	mm	g
00 8130 0000	240	240

### Handschutz für Meißel

Protective handles for chisels

Protecteurs pour burins

Protectores para cinceles

Bestell-Nr. Part No. Référence No. Referencia No.	Länge Length Longueur Largo	Zoll	Gewicht Weight Poids Peso
	mm		g
00 8140 0001	115	80	110
00 8140 0002	115	80	110

### Körner, achtkantig, DIN 7250

Center punch, octagonal, DIN 7250

Pointeau, octogonal, DIN 7250

Centro punzones, DIN 7250

Bestell-Nr. Part No. Référence No. Referencia No.	Länge Length Longueur Largo	Gewicht Weight Poids Peso
	mm	g
00 8200 0000	120	90

### Werkzeugsatz, im Metallkasten

Tool Assortment, in metal box

Jeux d'outils, en boîte metal

Juego de cinceles y punzones, en cajita de metal

Bestell-Nr. Part No. Référence No. Referencia No.	Inhalt Contents Composition Contenido	Gewicht Weight Poids Peso
		g
00 8260 0000	8100/5	620
	8100/6	
	8120/5	
	8150/2	
	8150/4	
	8200	

# 8130



No. 00 8140 0001 für/for/pour/para No. 8100 + 8120 ≥ 200 mm  
No. 00 8140 0002 für/for/pour/para No. 8130

# 8200



# 8260



8265



**Werkzeugsatz Splinttreiber, im Metallkasten**

Set of drift pins, in metal box

Jeu de chasse goupilles, en boîte metal

Juego de punzones, en cajita de metal

Bestell-Nr. Part No. Référence No. Referencia No.	Inhalt Contents Composition Contenido	Gewicht Weight Poids Peso
		g
00 8265 0000	8250/3	540
	8250/4	
	8250/5	
	8250/6	
	8250/7	
	8250/8	

8335



**Schraubenausdreher – Sätze**

Screw extractors, sets

Extracteurs de goujons, jeux

Extractores de tornillos, juegos

Bestell-Nr. Part No. Référence No. Referencia No.	Zusammenstellung assortment composition composición	Gewicht Weight Poids Peso
	mm	g
00 8335 0100	1 – 5	160
00 8335 0200	1 – 6	290
00 8335 0300	1 – 8	970

**Schraubenausdreher, Einzelgrößen**

Screw Extractors, single parts

Extracteurs de goujons

Extractores de tornillos, sueltos

Bestell-Nr. Part No. Référence No. Referencia No.	Größe Size Dimens. Tamaño	Gewicht Weight Poids Peso
	mm	g
00 8336 0100	1	5
00 8336 0200	2	10
00 8336 0300	3	15
00 8336 0400	4	30
00 8336 0500	5	50
00 8336 0600	6	95
00 8336 0700	7	160
00 8336 0800	8	290

### Liliputsäge, für Metall und Holz

Handsaw, small type

Petite scie, bois et metal

Sierra de mano, tipo corto

Bestell-Nr. Part No. Référence No. Referencia No.		Länge Length Longueur Largo	Gewicht Weight Poids Peso
		mm	g
00 8401 0000		240	170
00 8401 0100	Ersatzblatt spare blade lame seul Hojas de repuesto	160	2

## 8401



### Universal-Radabzieher, zweiarmig

Pullers, universal, two arms

Extracteurs, universel, à 2 bras

Extractores, universales, de dos garras

Bestell-Nr. Part No. Référence No. Referencia No.	Spannweite Capacity Capacité Abertura	Gewicht Weight Poids Peso
	mm	g
00 8430 0100	80	1000
00 8430 0200	130	1150
00 8430 0300	160	2900
00 8430 0400	220	3300
00 8430 0500	250	7200
00 8430 0600	370	8900

## 8430



### Radabzieher, zwei- und dreiarmig

Pullers, 2 and 3 arms

Extracteurs, à 2 et 3 bras

Extractores, de 2 y 3 garras

Bestell-Nr. Part No. Référence No. Referencia No.	Spannweite Capacity Capacité Abertura	Gewicht Weight Poids Peso
	mm	g
00 8432 0100	150	800
00 8432 0200	200	2000
00 8433 0100	150	1100
00 8433 0200	200	2900

## 8432 - 8433



# KFZ- UND SPEZIAL-WERKZEUGE

AUTOMOTIVE AND SPECIAL TOOLS

OUTILS SPÉCIAUX POUR AUTOMOBILES

HERRAMIENTAS ESPECIALES PARA EL AUTOMOVIL

## 1 1020 - 1 1920



### KFZ- und Spezialwerkzeuge

Automotive and Special Tools

Outils Spéciaux pour automobiles

Herramientas especiales para el Automovil

Bestell-Nr. Part No. Référence No. Referencia No.		Länge Length Longueur Largo	Gewicht Weight Poids Peso
		mm	g
01 1020 0000	<b>Kreuzschlüssel PKW</b> <b>17 x 19 x 20, 64 x 22 mm</b> Four way rim wrenches Clé en croix tourisme Llaves de cruz	380	1500
01 1080 0200	<b>Reifenheber, gerade Form</b> Tire Levers, straight Demonte pneu, droit Levanta-neumaticos, recto	400	630
01 1200 0000	<b>Zündkerzenbürste, dreireihig</b> Spark plug brushes Brosse à bougies Cepillo para bujias	160	30
01 1290 0000	<b>Steckschlüsseleinsatz 1/2" für Ölfilter</b> <b>(Golf Diesel) KD 2067</b> Socket for oilfilter 1/2" drive, (Golf Diesel) Douille pour filtre à huile carré entraineur 1/2" utilisation, (Golf Diesel) Boca especial para filtro de aceite para Golf Diesel	52	400
01 1400 0000	<b>Magnetheber, Plastikheft, max. Zugkraft 1800 g</b> Magnet pick up, with plastic handle Doigt magnetique, manche plastique Elevador magnético, flexible, con mango de plástico	520	220
01 1540 0300	<b>Fühlerlehren 20-tlg., 0,05 - 1</b> Feeler gauges 20 blades Jauges d'épaisseur, 20 lamelles Galgas, 20 hojas	-	90
01 1765 0000	<b>Kabelmesser mit Plastik-Heft</b> Cable knife Couteaux d'électricien Navaja para cables	195	75
01 1780 0000	<b>Autolichtprüfer, 6 - 24 V</b> Car light tester 6 - 24 V Controlleur d'éclairage 6 à 24 V Destornillador comprobador 6 - 24 V	110	75
01 1800 0000	<b>Ölspritzkanne aus Metall mit Druckpumpe</b> <b>250 ccm</b> Force feed oil can, metal container Burette à huile à pompe Aceitera	-	180
01 1900 0000	<b>Drahtbürste</b> Wire brush Brosse à manche Cepillo de alambre	290	160
01 1920 0000	<b>Rollbandmaß, 2 m</b> Measuring tape, 2 metres Mesure à ruban, 2 mètres Cinta metrica, 2 m	-	70

## KFZ- und Spezialwerkzeuge

Automotive and Special Tools

Outils Spéciaux pour automobiles

Herramientas especiales para el Automovil

Bestell-Nr. Part No. Référence No. Referencia No.		Länge Length Longueur Largo	Gewicht Weight Poids Peso
		mm	g
01 1930 0100	<b>Werkzeughalter mit Knarre für Rechts- und Linksgang M 3 – M 8</b> Tool ratchet for right and left thread Porte outils a cliquet droite et gauche Giramachos derecho/izquierda	80	180
01 1930 0200	<b>Werkzeughalter mit Knarre für Rechts- und Linksgang M 5 – M 12</b> Tool ratchet for right and left thread Porte outils a cliquet droite et gauche Giramachos derecho/izquierda	105	310
01 1950 0000	<b>Hebeleisen zum Anheben des Zylinderkopfes</b> Universal iron lever for loosening cylinder heads Lever universel pour decoller culasses etc. Palanca universal para levantar cabezas cilindricas	400	510
01 1955 0000	<b>Steckschlüsseinsatz, KD 3077</b> Socket for fitting Douille pour montage Boca para montaje	82	100
01 1960 0000	<b>Steckschlüsseinsatz, KD 3078</b> Socket for fitting Douille pour montage Boca para montaje	82	120
01 1965 0000	<b>Gegenhalter zur Montage der hinteren Federbeine (alle VW) KD 3079</b> Counter holder fitting rear suspension holder (VW) Barre de reaction montage de la barre de torsion VW Barra de reaccion montaje de la barra de torsión (VW)	176	120

# 1 1930-1 1965



11930



11950



11955



11960



11965

# KFZ- UND SPEZIAL-WERKZEUGE

AUTOMOTIVE AND SPECIAL TOOLS

OUTILS SPÉCIAUX POUR AUTOMOBILES

HERRAMIENTAS ESPECIALES PARA EL AUTOMOVIL

## 1 1966 - 1 1978



11966



11967 - 11968



11978

### KFZ- und Spezialwerkzeuge

Automotive and Special Tools

Outils Spéciaux pour automobiles

Herramientas especiales para el Automovil

Bestell-Nr. Part No. Référence No. Referencia No.		Länge Length Longueur Largo	Gewicht Weight Poids Peso
		mm	g
01 1966 0000	<b>Montagewerkzeug für Kolbenbolzen (VW Transporter) KD 3091</b> Fitting tool for piston pin (VW Transporter) Outil de montage pour axe de bielle Herramienta de montaje para ejes de biela	280	340
01 1967 0000	<b>Schlauchklemme für Kühlwasserschläuche (VW Transporter) KD 3094</b> Hose clamp for cooling water hoses (VW Transporter) Serre-tuyau pour fermer les tuyaux du circuit de refroidissement (VW Transporter) Abrazadera para manguera para cerrar tuberías del circuito de refrigeración (camión VW)	25	300
01 1968 0000	<b>Schlauchklemme für Kühlwasserschläuche (VW Transporter) KD 3093</b> Hose clamp for cooling water hoses (VW Transporter) Serre-tuyau pour fermer les tuyaux du circuit de refroidissement (VW Transporter) Abrazadera para manguera para cerrar tuberías del circuito de refrigeración (camión VW)	40	480
01 1978 0000	<b>Lehre für Torx-Schrauben</b> Selector for torx screws Sélecteur pour vis torx Selectores para tornillos torx	68	20

### Artikel-Nr.

Part No.  
Référence No.  
Referencia No.

<b>6630</b>	Schlosserhämmer, englische form Machinists' Hammers, english pattern Marteaux de serrurier, forme anglaise Martillos para mecánicos, tipe inglés
<b>6670</b>	Fäustel, nach DIN 6475 Double Face Sledge Hammers Massettes Mazas
<b>6675</b>	Vorschlaghämmer, nach DIN 1042 Sledge Hammers Marteaux à main Mazas
<b>8403/8405</b>	Metallsägen Hack Saws Scies à métaux Sierras para metales

Auf Anfrage / On request / Sur demande / A petición

## KFZ- und Spezialwerkzeuge

Automotive and Special Tools

Outils Spéciaux pour automobiles

Herramientas especiales para el Automovil

Bestell-Nr. Part No. Référence No. Referencia No.		Länge Length Longueur Largo	Gewicht Weight Poids Peso
		mm	g
6301 11005 (72013)	<b>Haushaltsschere, Edelstahl rostfrei, nachstellbar, für Rechts -und Linkshänder</b> Scissors, stainless refined steel, adjustable suitable for right- and left-use Ciseau inox Tijera universal	125	52
6301 11008 (72020)	<b>Haushaltsschere, Edelstahl rostfrei, nachstellbar, für Rechts -und Linkshänder</b> Scissors, stainless refined steel, adjustable suitable for right- and left-use Ciseau inox Tijera universal	200	120
644 1 11001	<b>Lötwasserflasche, gelb, mit Prägeschrift „Lötwasser“, Verschraubung blau, 150 ml</b> Soldering Fluid Bottle, yellow, with embossed lettering "Lötwasser" (Soldering fluid), blue cap Décapant, flacon Botella de plástico para líquido para soldar	-	38
644 1 11002	<b>Salzsäureflasche, blau, mit Prägeschrift „Salzsäure“, Verschraubung gelb, 150 ml</b> Hydrochlorid Acid Bottle, blue, with embossed lettering "Salzsäure" (Hydrochlorid acid), yellow cap Acide chlorhydrique Botella de plástico para ácido clorhídrico	-	38
644 1 20001	<b>Lötwasserpinsel, schwarze Chinaborste für Löt- wasser, Säuren, Öl, Klebstoffe, etc., 25 Stk. 9 mm</b> Soldering Fluid Brush, black China bristles, for soldering fluid, acids, oil, adhesives, etc, 25 pcs. Pinceau, 25 pieces Pincel para líquido para soldar, 25 piezas	120	102
644 1 20002	<b>Lötwasserpinsel, schwarze Chinaborste für Löt- wasser, Säuren, Öl, Klebstoffe, etc., 25 Stk. 11 mm</b> Soldering Fluid Brush, black China bristles, for soldering fluid, acids, oil, adhesives, etc, 25 pcs. Pinceau, 25 pieces Pincel para líquido para soldar, 25 piezas	130	116
644 1 20003	<b>Lötwasserpinsel, schwarze Chinaborste für Löt- wasser, Säuren, Öl, Klebstoffe, etc., 25 Stk. 12 mm</b> Soldering Fluid Brush, black China bristles, for soldering fluid, acids, oil, adhesives, etc, 25 pcs. Pinceau, 25 pieces Pincel para líquido para soldar, 25 piezas	135	134
644 1 20004	<b>Lötwasserpinsel, schwarze Chinaborste für Löt- wasser, Säuren, Öl, Klebstoffe, etc., 25 Stk. 14 mm</b> Soldering Fluid Brush, black China bristles, for soldering fluid, acids, oil, adhesives, etc, 25 pcs. Pinceau, 25 pieces Pincel para líquido para soldar, 25 piezas	140	172
645 1 10150	<b>Plastik-Ölkanne (Öl-Kerl) mit Drehverschluß und unverlierbarem Messingrohr, 125 ml</b> Plastic oil cans, with screw cap and permanently attached brass tube, 125 ml Burette huile, 125 ml, bec laiton Aceitera, 125 ml	-	38
645 1 10250	<b>Plastik-Ölkanne (Öl-Kerl) mit Drehverschluß und unverlierbarem Messingrohr, 250 ml</b> Plastic oil cans, with screw cap and permanently attached brass tube, 250 ml Burette huile, 250 ml, bec laiton Aceitera, 250 ml	-	50

# 6301 - 644 - 645



6301 (72013)



6301 (72020)



644/1



644/2



6441/1 - 4



645

# KFZ- UND SPEZIAL-WERKZEUGE

AUTOMOTIVE AND SPECIAL TOOLS

OUTILS SPÉCIAUX POUR AUTOMOBILES

HERRAMIENTAS ESPECIALES PARA EL AUTOMOVIL

## 6471



Raufilam



Rauclair

Weitere Abmessungen auf Anfrage  
Further dimensions on request  
Autres dimensions à la demande  
Otros dimensiones a petición

### KFZ- und Spezialwerkzeuge

Automotive and Special Tools

Outils Spéciaux pour automobiles

Herramientas especiales para el Automovil

Bestell-Nr. Part No. Référence No. Referencia No.		Länge Length Longueur Largo m	Ø
6471 10630	<b>Raufilam, druckfeste Schläuche, fadenarmiert, cadmiumfrei, Bauartgeprüft, 4-fache Sicherheit zum Berstdruck, Berstdruckprüfung, hervorragende Alterungsbeständigkeit, hohe Armierungsdichte, ausgezeichnete Abriebfestigkeit, nach EU-Richtlinien 90/128</b> Raufilam, pressure-resistant tubing, textile reinforcement, cadmium-free, tested, in accordance with EU directive 90/128 Tuyau Raufilam renforcé, fabriqués sans cadmium Manga Raufilam reforzada, fabricada sin cadmium	50/25	6 x 3
6471 10930		50/25	9 x 3
6471 11030		50/25	10 x 3
6471 11335		50/25	13,2 x 3,3
6471 11940		50/25	19,4 x 3,7
6471 12545		25/50	25,4 x 4,3
6471 00315	<b>Rauclair, glasklare Schläuche, cadmiumfrei</b> Rauclair, crystal clear, cadmium-free tubing Tuyau Rauclair transparent, fabriqués sans cadmium Manga Rauclair transparente, fabricada sin cadmium	100	3 x 1,5
6471 01330		50	13 x 3
6471 01940		50	19 x 4
6471 02540		50/25	25 x 4

Alle Rechte an Text, Bild und Aufmachung vorbehalten. SALTUS arbeitet stets an der Verbesserung seiner Erzeugnisse, deshalb können Abbildungen bzw. Angaben nicht immer der letzten Ausführung entsprechen und sind daher unverbindlich.

All rights reserved regarding text and pictures. SALTUS is continuously working on further improvements of their tools. Therefore, descriptions and pictures may not always correspond with the latest technical data.

Tous droits réservés quant aux textes, illustrations et descriptions. SALTUS travaille toujours à l'amélioration de ses produits, les illustrations et descriptions ne correspondent pas toujours à la dernière exécution et sont de ce fait sans engagement. Les poids indiqués sont des valeurs moyennes et également sans engagement.

Nos reservamos el derecho a efectuar las modificaciones que aconsejen las constantes investigaciones para el perfeccionamiento de SALTUS productos, por lo tanto, es posible que los textos e imágenes de este catálogo no corresponden a la última fabricación.

© by SALTUS 3/3/2 BH/HK

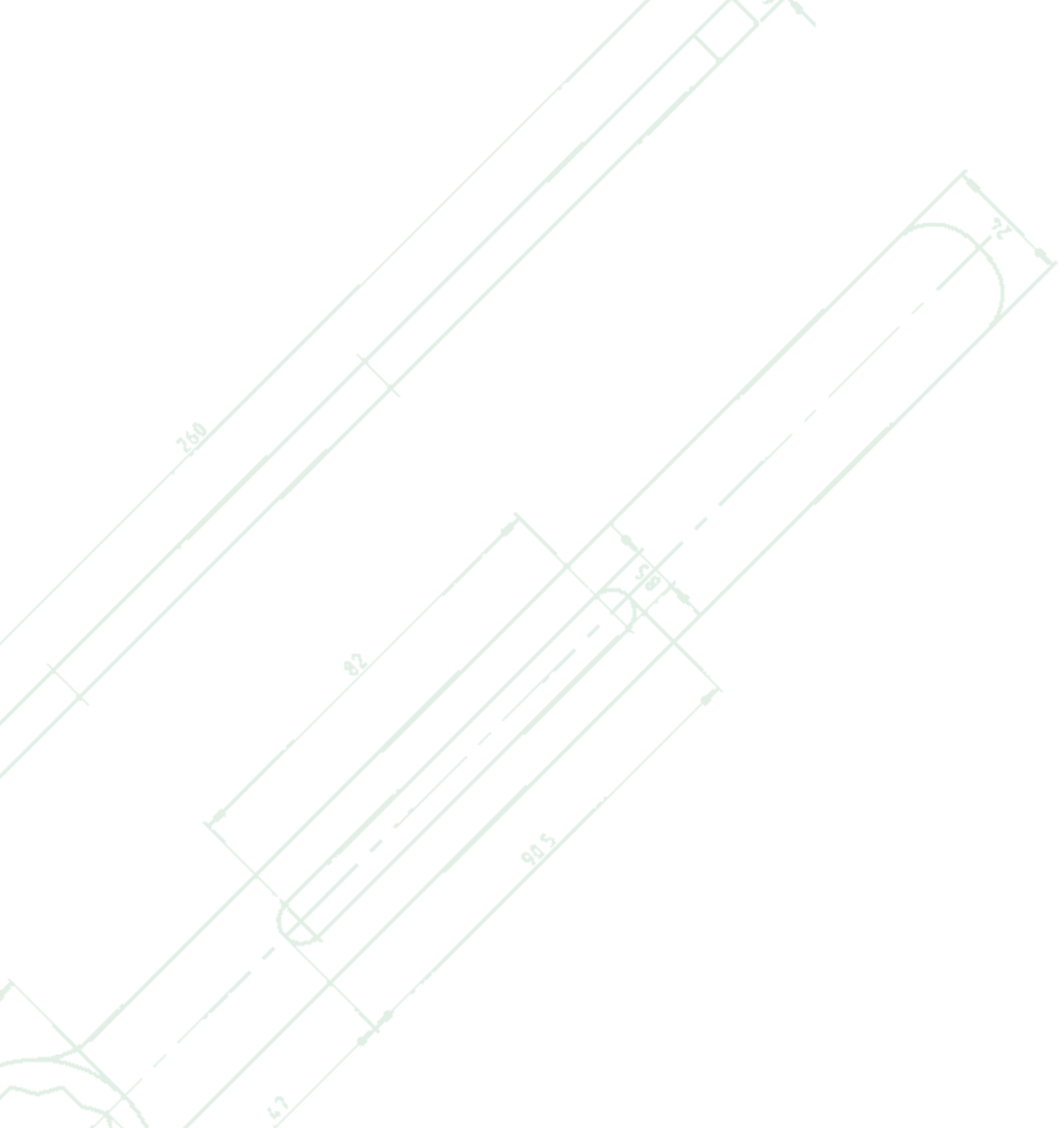

**SALTUS**<sup>®</sup>  
SOLINGEN - GERMANY

PRÄZISION IN DER TECHNIK

SALTUS-WERK Max Forst GmbH  
Schaberger Str. 49-53, D-42659 Solingen  
Postfach 10 02 26, D-42612 Solingen  
Tel. +49 (0) 2 12 59 60-220  
Fax +49 (0) 2 12 59 60-222  
Internet [www.saltus.de](http://www.saltus.de)  
eMail [tools@saltus.de](mailto:tools@saltus.de)

Ein Unternehmen der SALTUS Technology AG